

DUYAR 

Ürün Kataloğu
Product Catalogue



DUYAR TURQUALITY®'DE!

Global bir marka olabilme potansiyeline sahip Türk firmalarına, kurumsallaşma ve markalaşma yolunda destek sağlayarak, uluslararası pazarlarda kendi markalarıyla söz sahibi birer oyuncu olabilmeleri ve söz konusu markalar aracılığıyla olumlu Türk malı imajının yaratılması ve yerleştirilmesi amacıyla oluşturulmuş, devlet destekli markalaşma programı olan TURQUALITY®'ye, sektöründe girmeyi başarabilen ilk ve tek firma olmanın gururunu yaşamaktayız.



İÇİNDEKİLER / INDEX

STATİK BALANS VANASI FLANŞLI (PN 16) - STATIC BALANCING VALVE FLANGED (PN 16)	1
STATİK BALANS VANASI BRONZ DİŞLİ (PN 25) - STATIC BALANCING VALVE BRONZE THREADED (PN 25)	2
LUG KÜRESEL VANA (PN 16) - LUG BALL VALVE (PN 16)	3
TAM GEÇİŞLİ KÜRESEL VANA (2 PARÇALI PN 6) - FULL BORE BALL VALVE (2 PCS PN 6)	4
TAM GEÇİŞLİ KÜRESEL VANA (2 PARÇALI PN 16) - FULL BORE BALL VALVE (2 PCS PN 16)	5
TAM GEÇİŞLİ KÜRESEL VANA (2 PARÇALI PN16) - FULL BORE BALL VALVE (2 PCS PN16)	6
TAM GEÇİŞLİ KÜRESEL VANA (3 PARÇALI PN 16) - FULL BORE BALL VALVE (3 PCS PN 16)	7
TAM GEÇİŞLİ KÜRESEL VANA (DİŞLİ PN 16) - FULL BORE BALL VALVE (THREADED PN 16)	8
GAZ KÜRESEL VANA (3 PARÇALI MOP 5HVAC20 / PN 16 / PN 25) - GAS BALL VALVE (3 PCS MOP 5HVAC20 / PN 16 / PN 25)	9
METAL YATAKLI SÜRGÜLÜ VANA (PN 16, F4) - METAL SEATED GATE VALVE (PN 16, F4)	11
ELASTOMER SİTLİ SÜRGÜLÜ VANA (PN 16, F4) - RESILIENT SEATED GATE VALVE (PN 16, F4)	12
ELASTOMER SİTLİ SÜRGÜLÜ VANA (PN 16, F4) - RESILIENT SEATED GATE VALVE (PN 16, F4)	13
ELASTOMER SİTLİ SÜRGÜLÜ VANA (PN 16, F5) - RESILIENT SEATED GATE VALVE (PN 16, F5)	14
YÜKSELEN MİLLİ METAL YATAKLI SÜRGÜLÜ VANA (F4) - OS&Y METAL SEATED GATE VALVE (F4)	15
BUŞAKLE TAKIMI - SURFACE BOX	16
WAFER KELEBEK VANA (PN 25) - WAFER BUTTERFLY VALVE (PN 25)	17
KAUÇUK KAPLI WAFER KELEBEK VANA (PN 16) - RUBBER COATED WAFER BUTTERFLY VALVE (PN 16)	18
WAFER VULKANİZE KELEBEK VANA (NİKEL KLAPELİ, PN16) - WAFER VULCANIZED BUTTERFLY VALVE (NICKEL CLAPPER, PN16)	19
WAFER VULKANİZE KELEBEK VANA (PASLANMAZ KLAPELİ, PN 16) - WAFER VULCANIZED BUTTERFLY VALVE (STAINLESS STEEL CLAPPER, PN 16)	20
LUG KELEBEK VANA (NİKEL KLAPELİ, PN 16) - LUG BUTTERFLY VALVE (NICKEL PLATED, PN 16)	21
LUG KELEBEK VANA (PASLANMAZ KLAPELİ, PN 16) - LUG BUTTERFLY VALVE (STAINLESS STEEL CLAPPER, PN 16)	22
KELEBEK VANA DİŞLİ KUTULARI (REDÜKTÖR) - BUTTERFLY VALVE GEAR BOXES	23
GLOB VANA (PN 16) - GLOBE VALVE (PN 16)	24
METAL KÖRÜKLÜ GLOB VANA (PN 40) - METAL BELLOWS SEALED GLOBE VALVE (PN 40)	25
METAL KÖRÜKLÜ GLOB VANA (PN 16) - METAL BELLOWS SEALED GLOBE VALVE (PN 16)	26
TAM KALKIŞLI EMNİYET VENTİLİ (YAYLI, PN 16) - FULL LIFT SAFETY VALVE (WITH SPRING, PN 16)	27
ORANSAL KALKIŞLI EMNİYET VENTİLİ (YAYLI, PN 16) - PROPORTIONAL LIFT SAFETY VALVE (WITH SPRING, PN 16)	28
TERS KOVALI KONDENSTOP (FLANŞLI - DİŞLİ, PN 16) - INVERTED BUCKET STEAM TRAP (FLANGED - THREADED, PN 16)	29
DİSK TİP ÇEK VANA PİRİNÇ (PN 16) - DISC TYPE CHECK VALVE BRASS (PN 16)	31
DİSK TİP ÇEK VANA SFERO DÖKÜM (PN 16) - DISC TYPE CHECK VALVE DUCTILE IRON (PN 16)	32
ÇİFT KLAPELİ ÇEK VALF (PN 16) - DUAL PLATE CHECK VALVE (PN 16)	33
YAYLI ÇEK VANA (PN 16) - CHECK VALVE (WITH SPRING PN 16)	34
ÇALPARA ÇEK VANA (PN 16) - SWING CHECK VALVE (PN 16)	35
WAFER ÇALPARA ÇEK VALF (PN 16) - WAFER SWING CHECK VALVE (PN 16)	36
LUG PİSLİK TUTUCU (PN 16) - LUG STRAINER (PN 16)	37
Y TİPİ PİSLİK TUTUCU (PN 16) - Y TYPE STRAINER (PN 16)	38
YER ÜSTÜ YANGIN HİDRANTI (PN 16)HVACOVERGROUND FIRE HYDRANT (PN 16)	39
YER ÜSTÜ YANGIN HİDRANTI (PN 16)HVACOVERGROUND FIRE HYDRANT (PN 16)	40
YER ALTI YANGIN HİDRANTI (PN 16)HVACUNDERGROUND FIRE HYDRANT (PN 16)	41
KAUÇUK KOMPANSATÖR (FLANŞLI, PN 16) - RUBBER EXPANSION JOINT (FLANGED, PN 16)	43
KAUÇUK KOMPANSATÖR (DİŞLİ, PN 16) - RUBBER EXPANSION JOINT (THREADED, PN 16)	44
METAL KÖRÜKLÜ KOMPANSATÖR (DÖNER FLANŞLI, LAYNERSİZ, PN 16) - METAL BELLOWS EXPANSION JOINTS (ROTARY FLANGED, WITHOUT LINER, PN 16)	45
METAL KÖRÜKLÜ KOMPANSATÖR (DÖNER FLANŞLI, LAYNERLİ, PN 16) - METAL BELLOWS EXPANSION JOINTS (ROTARY FLANGED, WITH LINER, PN 16)	46
METAL KÖRÜKLÜ KOMPANSATÖR (KAYNAK BOYUNLU, LAYNERSİZ, PN 16) - METAL BELLOWS EXPANSION JOINTS (WELDING NECK, WITHOUT LINER, PN 16)	47
METAL KÖRÜKLÜ KOMPANSATÖR (DIŞTAN BASINÇLI, FLANŞLI, PN 16) - METAL BELLOWS EXPANSION JOINTS (EXTERNAL PRESSURED, FLANGED, PN 16)	48
METAL KÖRÜKLÜ KOMPANSATÖR, DIŞTAN BASINÇLI (KAYNAK BOYUNLU, PN 16) - METAL BELLOWS EXPANSION JOINTS, EXTERNALLY PRESSURED (WITH WELDING NECK, PN 16)	49
DİLATASYON KOMPANSATÖRLERİ, LİMİT ROTLU (FLANŞLI) - DILATATION EXPANSION JOINTS, WITH LIMITING ROD (FLANGED)	50
DİLATASYON VE DEPREM (SİSMİK) KOMPANSATÖRLERİ (FLANŞLI, PN 16) - DILATATION AND EARTHQUAKE (SEISMIC) EXPANSION JOINTS (FLANGED, PN 16)	51
DİLATASYON VE DEPREM (SİSMİK) KOMPANSATÖRLERİ (KAYNAK BOYUNLU, PN 16) - DILATATION AND EARTHQUAKE (SEISMIC) EXPANSION JOINTS (WITH WELDING NECK, PN 16)	52
DİLATASYON KOMPANSATÖRLERİ, LİMİT ROTLU (FLANŞLI, PN 16) - DILATATION EXPANSION JOINTS, WITH LIMITING ROD (FLANGED, PN 16)	53
DİLATASYON KOMPANSATÖRLERİ, LİMİT ROTLU (KAYNAK BOYUNLU, PN 16) - DILATATION EXPANSION JOINTS, WITH LIMITING ROD (WITH WELDING NECK, PN 16)	54
PİRİNÇ KÜRESEL VANA (DİŞLİ, PN 25) - BRASS BALL VALVE (THREADED, PN 25)	55
PİRİNÇ KÜRESEL VANA, KELEBEK KOLLU (DİŞLİ, PN 25) - BRASS BALL VALVE, WITH BUTTERFLY LEVER (THREADED, PN 25)	56
PİRİNÇ KÜRESEL VANA, İZOLASYON BOYUNLU (DİŞLİ, PN 25) - BRASS BALL VALVE, WITH STEM EXTENTION (THREADED, PN 25)	57
PİRİNÇ MİNİ KÜRESEL VANA (PN 16) - BRASS MINI BALL VALVE (PN 16)	58
PİRİNÇ YAYLI ÇEK VANA (DİŞLİ, PN 16) - BRASS CHECK VALVE WITH SPRING (THREADED, PN 16)	59
Y TİPİ PİSLİK TUTUCU (PİRİNÇ, DİŞLİ, PN 16) - Y TYPE STRAINER (BRASS, THREADED, PN 16)	60
OTOMATİK PURJÖR (PN 10) - AUTOMATIC AIR VENT (PN 10)	61

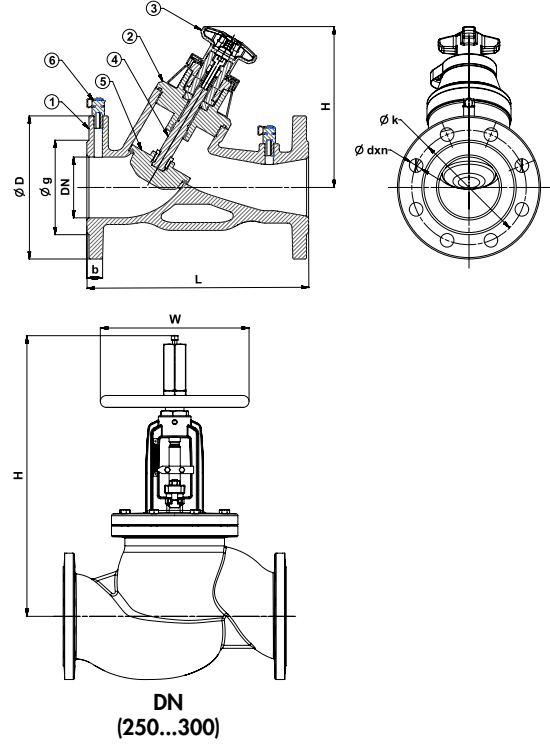

Genel Özellikler / General Specifications

Çalışma Sıcaklık Aralığı / Working Temperature : -10 ... +120 °C (16 Bar)

Standartlar / Standards

Sertifikalar / Certificates :

Tasarım / Design : TS EN 13789

Flanş Boyutları / Flange Dimensions : TS EN 1092-2 (PN 16)

Bağlantı Boyutları / Connection Dimensions : TS EN 1092-2 (PN 16)

Testler / Tests : TS EN 12266-1

Uygulamalar / Applications

Isıtma soğutma ve diğer su sistemleri

Heating and cooling systems and other water systems

Malzeme Özellikleri / Material Specifications	No	Parça Adı / Part Name	Malzeme / Material
	1	Gövde / Body	GG 25 - EN GJL 250 - Pik Döküm / Cast Iron
	2	Kapak / Bonnet	GG 25 - EN GJL 250 - Pik Döküm / Cast Iron
	3	Volan / Handwheel	DN 40-150, Ebonit / Ebonite, DN 200-300, GG 25 - EN GJL 250 - Pik Döküm / Cast Iron
	4	Mil / Stem	X20Cr13 - AISI420 - Paslanmaz Çelik / Stainless Steel
	5	Klape / Disc	GGG 40 - EN GJS 400-15 - Sfero Döküm + Kauçuk Kaplama / Ductile Iron + Rubber Coated
6	Ölçüm Probu / Measurement Probe	CuZn40Pb2 - CW617N - Pirinç / Brass	

Ölçüler / Dimensions	Anma Basıncı / Nominal Pressure	16 Bar											
	Anma Çapı / Nominal Diameter	DN	40	50	65	80	100	125	150	200	250	300	
	Vana Boyutları / Valve Dimensions	L	200	230	290	310	350	400	480	600	730	850	
		H	176	190	214	225	334	388	403	825	900	945	
		W	86					160			400		
		D	150	165	185	200	220	250	285	340	405	460	
		g	84	99	118	132	156	184	211	266	319	370	
		k	110	125	145	160	180	210	240	295	355	410	
	b	18	20		22		24	26		30	32		
	Ağırlık / Weight	Kg	8,65	11,60	15,8	20,45	36,45	69,2	95,6	182	275,8	311,5	

STATİK BALANS VANASI BRONZ DİŞLİ (PN 25)

-STATIC BALANCING VALVE BRONZE THREADED (PN 25)



T-3010 Bronz Döküm / Cast Bronze

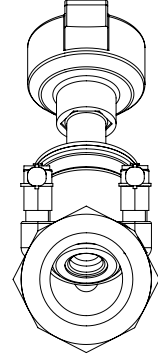
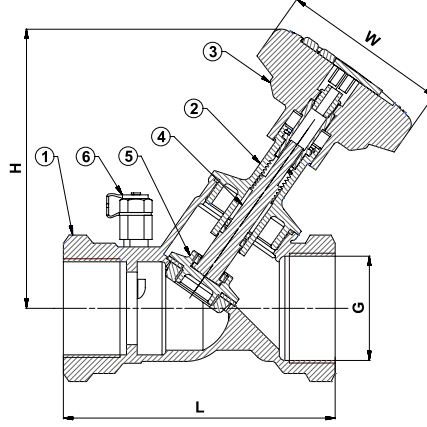

Genel Özellikler / General Specifications

Çalışma Sıcaklık Aralığı / Working Temperature : -10 ... +120 °C (25 Bar)

Standartlar / Standards

Diş Standardı / Thread Standard : ISO 7-1

Testler / Tests : TS EN 12266-1

Uygulamalar / Applications

Isıtma soğutma ve diğer su sistemleri
Heating and cooling systems and other water systems

No	Parça Adı / Part Name	Malzeme / Material
1	Gövde / Body	G-CuSn5Zn5Pb5 - Rg5 - Bronz Döküm / Cast Bronze
2	Kapak / Bonnet	CuZn40Pb2 - CW617N - Pirinç / Brass
3	Volan / Handwheel	Ebonit / Ebonite
4	Mil / Stem	CuZn40Pb2 - CW617N - Pirinç / Brass
5	Klape / Disc	CuZn40Pb2 - CW617N - Pirinç / Brass
6	Ölçüm Probu / Measurement probe	CuZn40Pb2 - CW617N - Pirinç / Brass

Ölçüler / Dimensions	Anma Basıncı / Nominal Pressure	25 Bar						
	Anma Çapı / Nominal Diameter	DN	15	20	25	32	40	50
Vana Boyutları / Valve Dimensions	G		1 / 2"	3 / 4"	1"	1 1 / 4"	1 1 / 2"	2"
	L		87	96	100	114	125	146
	H		105	106	125	128	143	144
	W		70					
Ağırlık / Weight	Kg		0,550	0,600	0,840	1,050	1,410	1,950

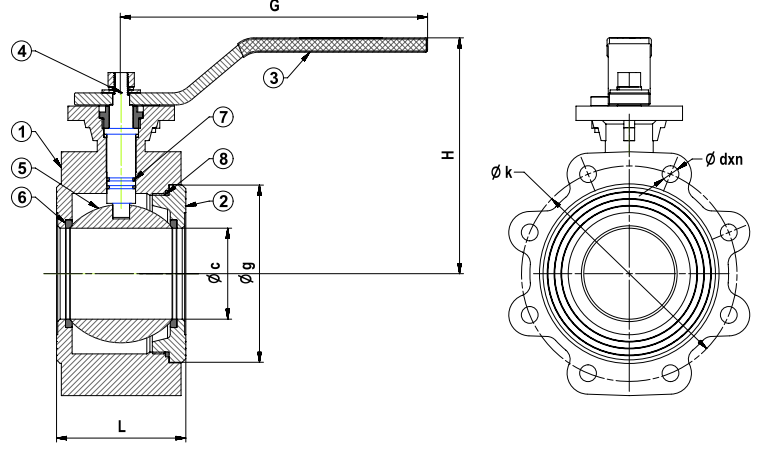

Genel Özellikler / General Specifications

Çalışma Sıcaklık Aralığı / Working Temperature : -10 ... +120 °C (16 Bar)

Standartlar / Standards

Sertifikalar / Certificates : CE P E

Tasarım / Design : TS 3148, EN ISO 17292

Flanş Boyutları / Flange Dimensions : TS EN 1092-2 (PN 16)

Testler / Tests : TS EN 12266-1

Uygulamalar / Applications

Sıcak ve soğuk su sistemleri, basınçlı hava, asit ve alkali özelliği bulunmayan sıvı akışkanlar
Hot and cold water systems, compressed air, non-acidic and non-flammable liquid fluids

Malzeme Özellikleri / Material Specifications	No	Parça Adı / Part Name	Malzeme / Material
	1	Gövde / Body	GGG 40 - EN GJS 400-15 - Sfero Döküm / Ductile Iron
	2	Kapak / Bonnet	GGG 40 - EN GJS 400-15 - Sfero Döküm / Ductile Iron
	3	Kol / Lever	Sr37 - Çelik / Steel
	4	Mil / Stem	X20Cr13 - AISI420 - Paslanmaz Çelik / Stainless Steel
	5	Küre / Ball	Paslanmaz Çelik / Stainless Steel
	6	Ringler / Seals	PTFE - Teflon
	7	O-Ring	EPDM
	8	O-Ring	EPDM

Ölçüler / Dimensions	Anma Basıncı / Nominal Pressure	16 Bar						
	Anma Çapı / Nominal Diameter	DN	65	80	100	125	150	200
	Vana Boyutları / Valve Dimensions	L	77	93	108	160	183	235
		G			255	335	400	
		H	140	151	197	223	255	285
		k	145	160	180	210	240	295
		g	115	130	150	184	214	266
		c	50	65	80	100	125	150
		dxn			M16x8		M20x8	M20x12
		Tepe Flanş* / Upper Flange			(ISO 5211) F07		(ISO 5211) F10	
Mil Karesi / Stem Square			□14		□17			
Ağırlık / Weight	Kg	5.7	8.4	11	18.7	34.2	71.2	

* Dişli kutusu ve aktüatör bağlantısına uygundur.

* (Suitable to fit with actuator and gear box).

TAM GEÇİŞLİ KÜRESEL VANA (2 PARÇALI PN 6)

-FULL BORE BALL VALVE (2 PCS PN 6)



T-0510 Pik Döküm / Cast Iron

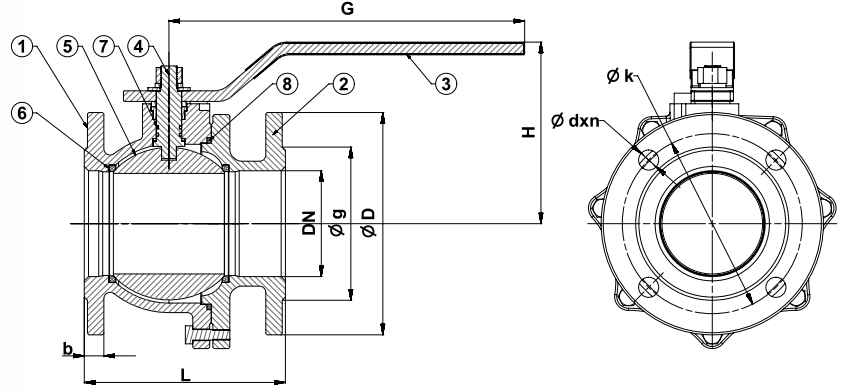

Genel Özellikler / General Specifications

Çalışma Sıcaklık Aralığı / Working Temperature : -10 ... +120 °C (6 Bar)

Standartlar / Standards

Tasarım / Design : TS 3148, EN ISO 17292

Flanş Boyutları / Flange Dimensions : TS EN 1092-2 (PN 6)

Alından Alına Boyutlar / Face to Face Dimensions : TS EN 558 (Seri 14)

Testler / Tests : TS EN 12266-1

Uygulamalar / Applications

Sıcak ve soğuk su sistemleri, basınçlı hava, asit ve alkali özelliği bulunmayan sıvı akışkanlar
Hot and cold water systems, compressed air, non-acidic and non-flammable liquid fluids

No	Parça Adı / Part Name	Malzeme / Material
1	Gövde / Body	GG 25 - EN GJL 250 - Pik Döküm / Cast Iron
2	Flanş / Flange	GG 25 - EN GJL 250 - Pik Döküm / Cast Iron
3	Kol / Lever	St37 - Çelik / Steel
4	Mil / Stem	X20Cr13 - AISI420 - Paslanmaz Çelik / Stainless Steel
5	Küre / Ball	Paslanmaz Çelik / Stainless Steel
6	Ringler / Seals	PTFE - Teflon
7	O-Ring	EPDM

Ölçüler / Dimensions	Anma Basıncı / Nominal Pressure	6 Bar					
	Anma Çapı / Nominal Diameter	DN	40	50	65	80	100
Vana Boyutları / Valve Dimensions	L		140	150	170	180	190
	G		190	260		335	
	H		120	130	140	155	170
	D		130	140	160	190	210
	k		100	110	130	150	170
	g		78	88	108	124	144
	b			16		18	
	dxn			14x4		19x4	
Ağırlık / Weight	Kg		5.5	6,7	9,8	14.5	18.5

T-0520 Pik Döküm / Cast Iron

T-0525 Sfero Döküm / Ductile Iron

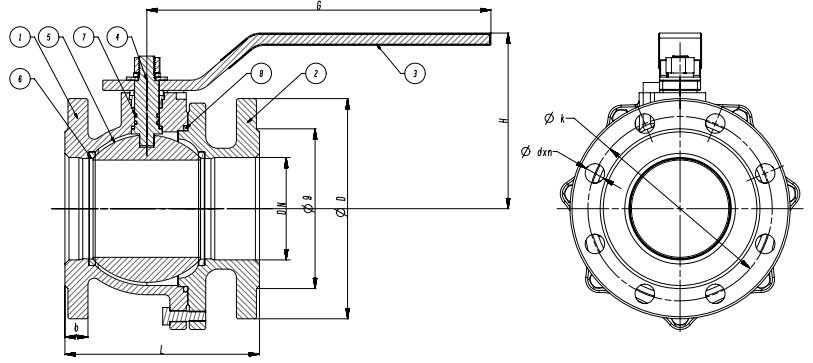

Genel Özellikler / General Specifications

Çalışma Sıcaklık Aralığı / Working Temperature : -10... +120 °C (16 Bar)

Standartlar / Standards

Sertifikalar / Certificates :

Tasarım / Design : TS 3148, EN ISO 17292

Flanş Bağlantı Ölçüleri / Flange Dimensions : TS EN 1092-2 (PN 16)

Alından Alına Boyutlar / Face to Face Dimensions : TS EN 558 (Seri 14)

Testler / Tests : TS EN 12266-1

Uygulamalar / Applications

Sıcak ve soğuk su sistemleri, basınçlı hava, asit ve alkali özelliği bulunmayan sıvı akışkanlar

Hot and cold water systems, compressed air, non-acidic and non-flammable liquid fluids

No	Parça Adı / Part Name	Malzeme / Material
1	Gövde / Body	GG 25 - EN GJL 250 - Pik Döküm / Cast Iron (T-0520) GGG 40 - EN GJS 400-15 - Sfero Döküm / Ductile Iron (T-0525)
2	Flanş / Flange	GG 25 - EN GJL 250 - Pik Döküm / Cast Iron (T-0520) GGG 40 - EN GJS 400-15 - Sfero Döküm / Ductile Iron (T-0525)
3	Kol / Lever	St37 - Çelik / Steel
4	Mil / Stem	X20Cr13 - AISI420 - Paslanmaz Çelik / Stainless Steel
5	Küre / Ball	Paslanmaz Çelik / Stainless Steel
6	Ringler / Seals	PTFE - Teflon
7	O-Ring / O-Ring	EPDM

Ölçüler / Dimensions	Anma Basıncı / Nominal Pressure	16 Bar									
	Anma Çapı / Nominal Diameter	DN	15	20	25	32	40	50	65	80	100
Vana Boyutları / Valve Dimensions	L	115	120	125	130	140	150	170	180	190	
	G	155		190		260		335			
	H	105		110	120	130	140	155	170		
	D	95	105	115	140	150	165	185	200	220	
	k	65	75	85	100	110	125	145	160	180	
	g	46	56	65	76	84	99	118	132	156	
	b	14	16		18		20		22	24	
dxn	14x4			19x4			19x8				
Ağırlık / Weight	kg	2.5	3	3.5	5.6	6.6	8.8	12	15.5	20.8	

TAM GEÇİŞLİ KÜRESEL VANA (2 PARÇALI PN 16)

-FULL BORE BALL VALVE (2 PCS PN 16)



T-0540 Pik Döküm / Cast Iron
T-0545 Sfero Döküm / Ductile Iron

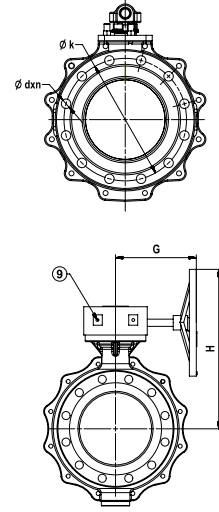
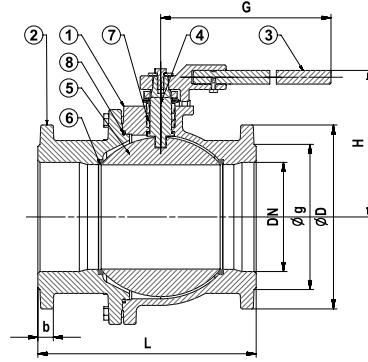

DN 250-300

Genel Özellikler / General Specifications

Çalışma Sıcaklık Aralığı / Working Temperature : -10 ... +120 °C (16 Bar)

Standartlar / Standards

Sertifikalar / Certificates :

Tasarım / Design : TS 3148, EN ISO 17292

Flanş Boyutları / Flange Dimensions : TS EN 1092-2 (PN 16)

Alından Alına Boyutlar / Face to Face Dimensions : TS EN 558 (Seri 15)

Testler / Tests : TS EN 12266-1

Uygulamalar / Applications

Sıcak ve soğuk su sistemleri, basınçlı hava, asit ve alkali özelliği bulunmayan sıvı akışkanlar
Hot and cold water systems, compressed air, non-acidic and non-flammable liquid fluids

Malzeme Özellikleri / Material Specifications	No	Parça Adı / Part Name	Malzeme / Material
	1	Gövde / Body	GG 25 - EN GJL 250 - Pik Döküm / Cast Iron (T-0540) GGG 40 - EN GJS 400-15 - Sfero Döküm / Ductile Iron (T-0545)
	2	Flanş / Flange	GG 25 - EN GJL 250 - Pik Döküm / Cast Iron (T-0540) GGG 40 - EN GJS 400-15 - Sfero Döküm / Ductile Iron (T-0545)
	3	Kol / Lever	St37 - Çelik / Steel
	4	Mil / Stem	X20Cr13 - AISI420 - Paslanmaz Çelik / Stainless Steel
	5	Küre / Ball	Paslanmaz Çelik / Stainless Steel
	6	Ringler / Seals	PTFE - Teflon
	7	Salmastra / Packing	PTFE - Teflon
	8	O-Ring	EPDM
9	Dişli Kutusu / Gear Box	GG 25 - EN GJL 250 - Pik Döküm / Cast Iron	

Ölçüler / Dimensions	Anma Basıncı / Nominal Pressure	16 Bar					
	Anma Çapı / Nominal Diameter	DN	125	150	200	*250	**300
	Vana Boyutları / Valve Dimensions	L	325	350	400	450	500
		G	335	700		280	
		H	190	250	280	555	
		D	250	285	340	405	460
		k	210	240	295	355	410
		g	184	211	266	319	370
		b	26		30	32	
dxn		19x8	23x8	23x12	28x12		
Ağırlık / Weight	Kg	32.6	72.6	84.2	187.4	196	

* DN 300 Redüksiyon geçişlidir. / Reduced Bore

** DN 250 ve DN 300 Dişli kutuludur. / With Gear Box

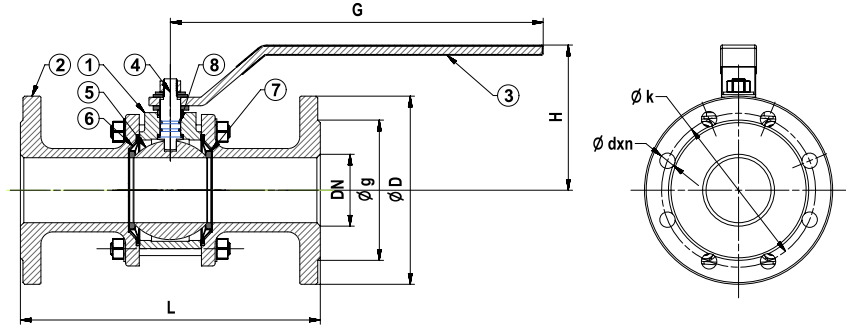

Genel Özellikler / General Specifications

Çalışma Sıcaklık Aralığı / Working Temperature : -10 ... +120 °C (16 Bar)

Standartlar / Standards

Sertifikalar / Certificates :

Tasarım / Design : TS 3148, EN ISO 17292

Flanş Boyutları / Flange Dimensions : TS EN 1092-2 (PN 16)

Alından Alına Boyutlar / Face to Face Dimensions : DN 15 - 125 TS EN 558 (Seri 1)

DN 150 - 200 TS EN 558 (Seri 27)

Testler / Tests : TS EN 12266-1

Uygulamalar / Applications

Sıcak ve soğuk su sistemleri, basınçlı hava, asit ve alkali özelliği bulunmayan sıvı akışkanlar
Hot and cold water systems, compressed air, non-acidic and non-flammable liquid fluids

Malzeme Özellikleri / Material Specifications	No	Parça Adı / Part Name	Malzeme / Material
	1	Gövde / Body	GG 25 - EN GJL 250 - Pik Döküm / Cast Iron
	2	Flanş / Flange	GG 25 - EN GJL 250 - Pik Döküm / Cast Iron
	3	Kol / Lever	St37 - Çelik / Steel
	4	Mil / Stem	X20Cr13 - AISI420 - Paslanmaz Çelik / Stainless Steel
	5	Küre / Ball	Paslanmaz Çelik / Stainless Steel
	6	Tabak Yayılar / Spring Seals	Paslanmaz Çelik + PTFE - Teflon / Stainless Steel + Teflon
	7	Ringler / Seals	PTFE - Teflon
	8	O-Ring	EPDM

Ölçüler / Dimensions	Anma Basıncı / Nominal Pressure	16 Bar													
	Anma Çapı / Nominal Diameter	DN	15	20	25	32	40	50	65	80	100	125	150	200	
	Vana Boyutları / Valve Dimensions	L	130	150	160	180	200	230	290	310	350	400	350	550	
		G	155			190			260			335			700
		H	105			110	120	130	140	155	170	190	245	280	
		D	95	105	115	140	150	165	185	200	220	250	285	340	
		k	65	75	85	100	110	125	145	160	180	210	240	295	
		g	46	56	65	76	84	99	118	132	156	184	211	266	
		b	14	16		18		20		22	24	26		30	
		dxn	14x4			19x4			19x8			23x8		23x12	
Ağırlık / Weight	Kg	2.3	3.8	4	6.5	8.4	13.5	20	27	40	63	82.5	116		

TAM GEÇİŞLİ KÜRESEL VANA (DIŞLI PN 16)

-FULL BORE BALL VALVE (THREADED PN 16)



T-0560 Sfero Döküm / Ductile Iron

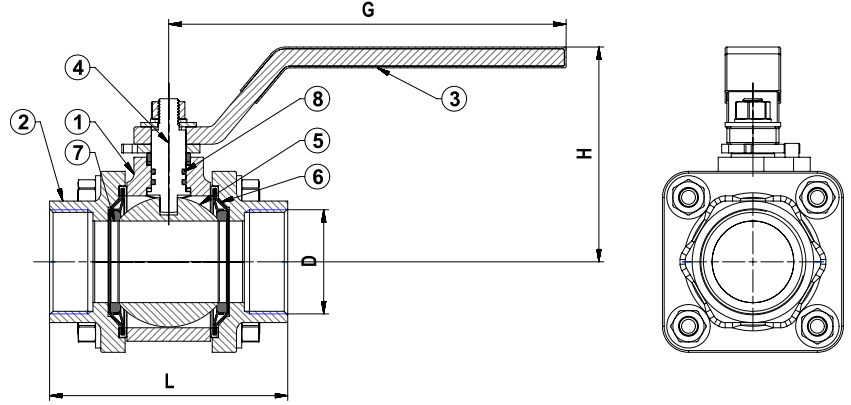

Genel Özellikler / General Specifications

Çalışma Sıcaklık Aralığı / Working Temperature : -10 ... +120 °C (16 Bar)

Standartlar / Standards

Sertifikalar / Certificates :

Tasarım / Design : TS 3148, EN ISO 17292

Diş Standardı / Thread Standard : EN ISO 228-1

Alından Alma Boyutları / Face to Face Dimensions : TS 3148 / 1

Testler / Tests : TS EN 12266-1

Uygulamalar / Applications

Sıcak ve soğuk su sistemleri, basınçlı hava, asit ve alkali özelliği bulunmayan sıvı akışkanlar
Hot and cold water systems, compressed air, non-acidic and non-flammable liquid fluids

Malzeme Özellikleri / Material Specifications	No	Parça Adı / Part Name	Malzeme / Material
	1	Gövde / Body	GGG 40 - EN GJS 400-15 - Sfero Döküm / Ductile Iron
	2	Flanş / Flange	GGG 40 - EN GJS 400-15 - Sfero Döküm / Ductile Iron
	3	Kol / Lever	St37 - Çelik / Steel
	4	Mil / Stem	X20Cr13 - AISI420 - Paslanmaz Çelik / Stainless Steel
	5	Küre / Ball	Paslanmaz Çelik / Stainless Steel
	6	Tabak Yayılar / Spring Seals	Paslanmaz Çelik + PTFE - Teflon / Stainless Steel + Teflon
	7	Ringler / Seals	PTFE - Teflon
8	O-Ring	EPDM	

Ölçüler / Dimensions	Anma Basıncı / Nominal Pressure	16 Bar							
	Anma Çapı / Nominal Diameter	DN	15	20	25	32	40	50	65*
	Vana Boyutları / Valve Dimensions	D	1 / 2"	3 / 4"	1"	1 1 / 4"	1 1 / 2"	2"	2 1 / 2"
		L	75	80	90	110	120	140	155
		G		155			190		260
H			105		110	120	130	140	
Ağırlık / Weight	Kg		0.6	1	1.5	2.4	4.4	7.5	8.2

* İki parçalıdır.

* (Two piece)

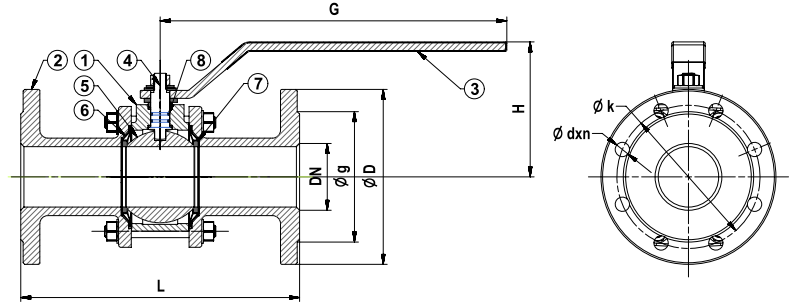

Genel Özellikler / General Specifications

Çalışma Sıcaklık Aralığı / Working Temperature : -10 ... +60 °C (25 Bar)

Standartlar / Standards

Sertifikalar / Certificates :

Tasarım / Design : TS EN 331, TS 9809

Flanş Boyutları / Flange Dimensions : TS EN 1092-2 (MOP 5-20 / PN 16 / 25)

Alından Alına Boyutlar / Face to Face Dimensions : DN 15 - 100 TS EN 558

(Seri 1) DN 125 - 200 TS EN 558 (Seri 26)

Testler / Tests : TS EN 12266-1, TS EN 331

Uygulamalar / Applications

Basıncılı gazlar, sıvı yakıtlar, doğal gaz ve LPG

Pressured gases, liquid fuels, natural gas and LPG

No	Parça Adı / Part Name	Malzeme / Material
1	Gövde / Body	GGG 40-ENGJS 400-15-Sfero Döküm / Ductile Iron
2	Flanş / Flange	GGG 40-ENGJS 400-15-Sfero Döküm / Ductile Iron
3	Kol / Lever	St37 - Çelik / Steel
4	Mil / Stem	X20Cr13 - AISI420 - Paslanmaz Çelik / Stainless Steel
5	Küre / Ball	Paslanmaz Çelik / Stainless Steel
6	Tabak Yayılar / Spring Seals	X5CrNi18 10 - AISI304 - Paslanmaz Çelik + PTFE - Teflon / Stainless Steel + PTFE - Teflon
7	Ringler / Seals	PTFE - Teflon
8	O-Ring	VİTON

Ölçüler / Dimensions	Anma Basıncı / Nominal Pressure	MOP 5 - 20			16 Bar			25 Bar	
	Anma Çapı / Nominal Diameter	DN	65	80	100	125	150	200	
Vana Boyutları / Valve Dimensions	L	290	310	350	400	450	550		
	G	260	335			700			
	H	140	155	170	190	245	280		
	D	185	200	220	270	300	360		
	k	145	160	180	220	250	310		
	g	118	132	156	184	211	274		
	b	20	22	24	26	28	30		
	dxn	19x4	19x8		28x8		28x12		
Ağırlık / Weight	Kg	14,9	21,3	32,8	62,4	96,8	116		

5 KİTAYA İHRACAT • % 100 YERLİ



444 VANA (8262)
duyaryana.com.tr

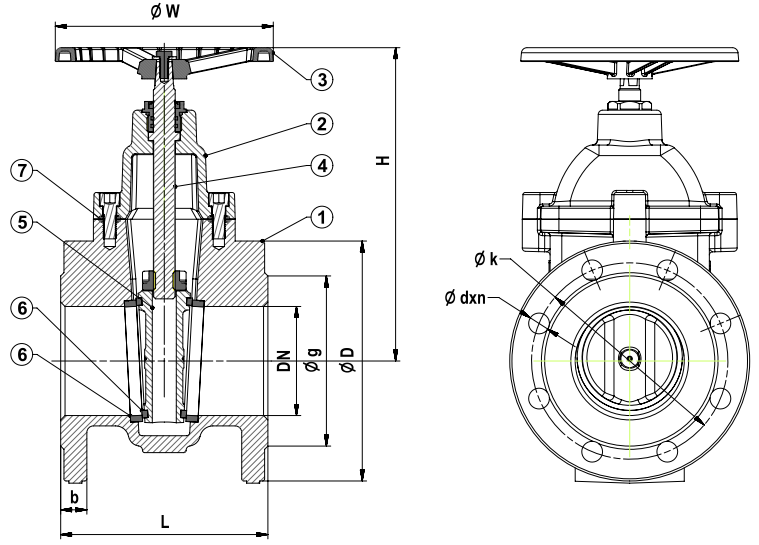

Genel Özellikler / General Specifications

Çalışma Sıcaklık Aralığı / Working Temperature : -10 ... +120 °C
2,5 / 4 / 10 / (16 Bar)

Standartlar / Standards

Sertifikalar / Certificates :

Tasarım / Design : TS EN 1171

Flanş Boyutları / Flange Dimensions : TS EN 1092-2 (PN 10)

Alından Alına Boyutlar / Face to Face Dimensions : TS EN 558 (Seri 14)

Testler / Tests : TS EN 12266-1

Uygulamalar / Applications

Sıcak ve soğuk su sistemleri, asit ve alkali özelliği bulunmayan sıvı akışkanlar
Hot and cold water systems, non-acidic and non-flammable liquid fluids

Malzeme Özellikleri / Material Specifications	No	Parça Adı / Part Name	Malzeme / Material
	1	Gövde / Body	GG 25 - EN GJL 250 - Pik Döküm / Cast Iron (T-1320)
	2	Kapak / Bonnet	GG 25 - EN GJL 250 - Pik Döküm / Cast Iron (T-1320)
	3	Volan / Handwheel	GG 25 - EN GJL 250 - Pik Döküm / Cast Iron
	4	Mil / Stem	X20Cr13 - AISI420 - Paslanmaz Çelik / Stainless Steel
	5	Sürgü / Wedge	GGG 40 - EN GJS 400-15 - Sfero Döküm / Ductile Iron
	6	Sitler / Seats	CuZn40Pb2 - CW617N - Pirinç - Paslanmaz Çelik - Bronz / Brass - Stainless Steel - Bronze
	7	Conta / Gasket	EPDM - NBR

Ölçüler / Dimensions	Anma Basıncı / Nominal Pressure	10 Bar								6 Bar				4 Bar			2,5 Bar
	Anma Çapı / Nominal Diameter	DN	40	50	65	80	100	125	150	200	250	300	350	400	500	600	
	L	140	150	170	180	190	200	210	230	250	270	290	310	350	390		
	H	170	180	230	245	265	355	400	490	615	700	835	910	1135	1300		
	W	160				200	250			315			400		500		
	D	150	165	185	200	220	250	285	340	395	445	505	565	670	780		
	k	110	125	145	160	180	210	240	295	350	400	460	515	620	725		
	g	84	99	118	132	156	184	211	266	319	370	429	480	582	682		
	b	18	20		22	24	26			28		30	32	34	36		
	dxn	19x4			19x8			23x8			23x12		23x16	28x16	28x20	31x20	
Ağırlık / Weight	Kg	9	10	15	17	23	37	45	80	123	166	225	368	460	680		

ELASTOMER SİTLİ SÜRGÜLÜ VANA (PN 16, F4)

-RESILIENT SEATED GATE VALVE (PN 16, F4)



T-1430 Pik Döküm / Cast Iron
T-1435 Sfero Döküm / Ductile Iron

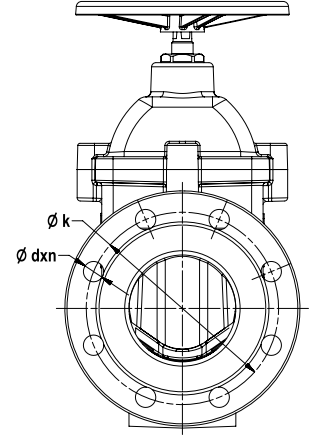
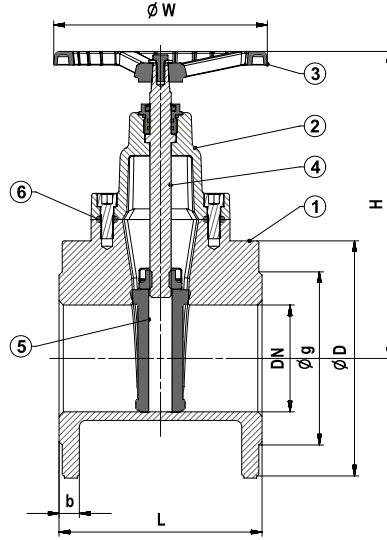

Genel Özellikler / General Specifications

Çalışma Sıcaklık Aralığı / Working Temperature : -10 ... +110 °C (16 Bar)

Standartlar / Standards

Sertifikalar / Certificates :

Tasarım / Design : TS EN 1171

Flans Boyutları / Flange Dimensions : TS EN 1092-2 (PN 16)

Alından Alına Boyutlar / Face to Face Dimensions : TS EN 558 (Seri 14)

Testler / Tests : TS EN 12266-1

Uygulamalar / Applications

Sıcak ve soğuk su sistemleri, asit ve alkali özelliği bulunmayan sıvı akışkanlar
Hot and cold water systems, non-acidic and non-flammable liquid fluids

Malzeme Özellikleri / Material Specifications	No	Parça Adı / Part Name	Malzeme / Material
	1	Gövde / Body	GG 25 - EN GJL 250 - Pik Döküm / Cast Iron (T-1430) DN 40-300 GGG 40 - EN GJS 400-15 - Sfero Döküm / Ductile Iron (T-1435)
	2	Kapak / Bonnet	GG 25 - EN GJL 250 - Pik Döküm / Cast Iron (T-1430) DN 40-300 GGG 40 - EN GJS 400-15 - Sfero Döküm / Ductile Iron (T-1435)
	3	Volan / Handwheel	GG 25 - EN GJL 250 - Pik Döküm / Cast Iron
	4	Mil / Stem	X20Cr13 - AISI420 - Paslanmaz Çelik / Stainless Steel
	5	Sürgü / Wedge	GGG 40 - EN GJS 400-15 - Sfero Döküm + Kauçuk Kaplı / Ductile Iron + Rubber Coated
	6	Conta / Gasket	EPDM - NBR

Ölçüler / Dimensions	Anma Basıncı / Nominal Pressure	16 Bar														
	Anma Çapı / Nominal Diameter	DN	40	50	65	80	100	125	150	200	250	300	350	400	500	600
	Vana Boyutları / Valve Dimensions	L	140	150	170	180	190	200	210	230	250	270	290	310	350	390
		H	170	180	230	245	265	355	400	490	615	700	835	910	1120	1330
		W	160				200	250			315			400		500
		D	150	165	185	200	220	250	285	340	405	460	520	580	715	840
		k	110	125	145	160	180	210	240	295	355	410	470	525	650	770
		g	84	99	118	132	156	184	211	266	319	370	429	480	609	720
		b	18	20		22	24	26		30	32		36	38	42	48
		dxn	19x4				19x8			23x8	23X12	28x12		28x16	31x16	34x20
Ağırlık / Weight	Kg	9	10	15	17	23	37	45	80	123	166	200	310	370	620	

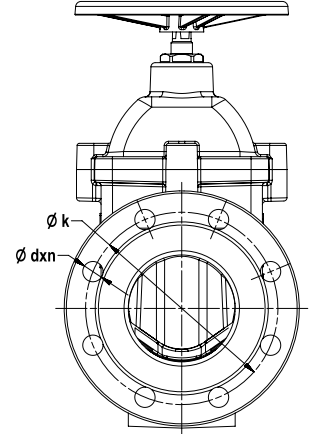
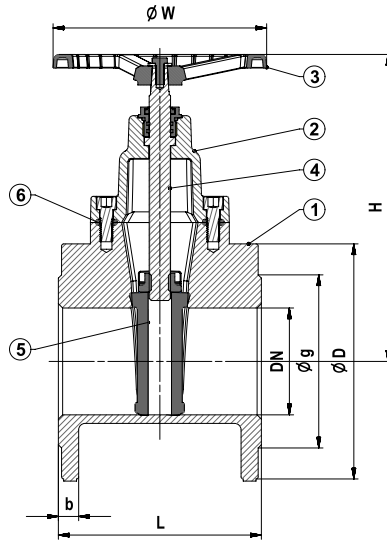

Genel Özellikler / General Specifications

Çalışma Sıcaklık Aralığı / Working Temperature : -10 ... +110 °C (16 Bar)

Standartlar / Standards

Sertifikalar / Certificates :

Tasarım / Design : TS EN 1171

Flanş Boyutları / Flange Dimensions : TS EN 1092-2 (PN 16)

Alından Alına Boyutları / Face to Face Dimensions : TS EN 558 (Seri 14)

Testler / Tests : TS EN 12266-1

Uygulamalar / Applications

Sıcak ve soğuk su sistemleri, asit ve alkali özelliği bulunmayan sıvı akışkanlar
Hot and cold water systems, non-acidic and non-flammable liquid fluids

Malzeme Özellikleri / Material Specifications	No	Parça Adı / Part Name	Malzeme / Material
	1	Gövde / Body	GG 25 - EN GJL 250 - Pik Döküm / Cast Iron (T-1430) DN 40-300 GGG 40 - EN GJS 400-15 - Sfero Döküm / Ductile Iron (T-1435)
	2	Kapak / Bonnet	GG 25 - EN GJL 250 - Pik Döküm / Cast Iron (T-1430) DN 40-300 GGG 40 - EN GJS 400-15 - Sfero Döküm / Ductile Iron (T-1435)
	3	Volan / Handwheel	GG 25 - EN GJL 250 - Pik Döküm / Cast Iron
	4	Mil / Stem	X20Cr13 - AISI420 - Paslanmaz Çelik / Stainless Steel
	5	Sürgü / Wedge	GGG 40 - EN GJS 400-15 - Sfero Döküm + Kauçuk Kaplı / Ductile Iron + Rubber Coated
	6	Conta / Gasket	EPDM - NBR

Ölçüler / Dimensions	Anma Basıncı / Nominal Pressure	16 Bar										
	Anma Çapı / Nominal Diameter	DN	40	50	65	80	100	125	150	200	250	300
	Vana Boyutları / Valve Dimensions	L	140	150	170	180	190	200	210	230	250	270
		H	170	180	230	245	265	355	400	490	615	700
		W	160			200	250		315			
		D	150	165	185	200	220	250	285	340	405	460
		k	110	125	145	160	180	210	240	295	355	410
		g	84	99	118	132	156	184	211	266	319	370
		b	18	20		22	24	26		30	32	
		dxn	19x4			19x8			23x8	23X12	28x12	
Ağırlık / Weight	Kg	9	10	15	17	23	37	45	80	123	166	

ELASTOMER SİTLİ SÜRGÜLÜ VANA (PN 16, F5)

-RESILIENT SEATED GATE VALVE (PN 16, F5)



T-1440 Pik Döküm / Cast Iron
T-1445 Sfero Döküm / Ductile Iron

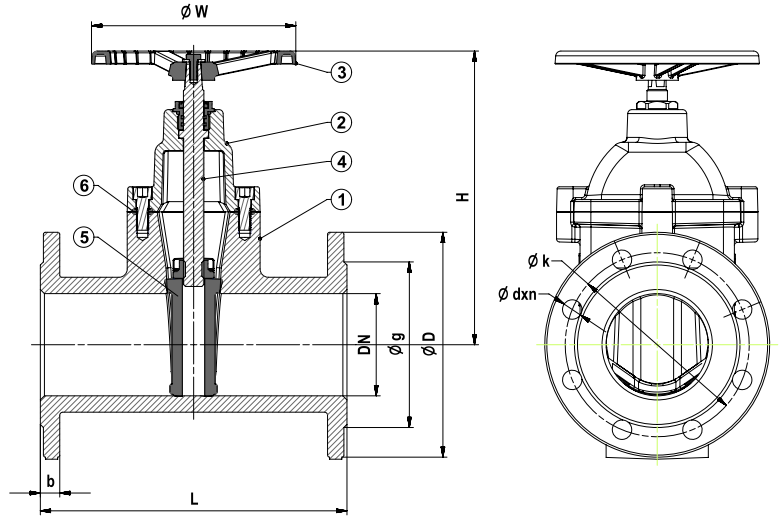

Genel Özellikler / General Specifications

Çalışma Sıcaklık Aralığı / Working Temperature : -10 ... +110 °C (16 Bar)

Standartlar / Standards

Sertifikalar / Certificates :

Tasarım / Design : TS EN 1171

Flanş Boyutları / Flange Dimensions : TS EN 1092-2 (PN 16)

Alından Alına Boyutlar / Face to Face Dimensions : TS EN 558 (Seri 15)

Testler / Tests : TS EN 12266-1

Uygulamalar / Applications

Sıcak ve soğuk su sistemleri, asit ve alkali özelliği bulunmayan sıvı akışkanlar
Hot and cold water systems, non-acidic and non-flammable liquid fluids

Malzeme Özellikleri / Material Specifications	No	Parça Adı / Part Name	Malzeme / Material
	1	Gövde / Body	GG 25 - EN GJL 250 - Pik Döküm / Cast Iron (T-1440) DN 40-300 GGG 40 - EN GJS 400-15 - Sfero Döküm / Ductile Iron (T-1445)
	2	Kapak / Bonnet	GG 25 - EN GJL 250 - Pik Döküm / Cast Iron (T-1440) DN 40-300 GGG 40 - EN GJS 400-15 - Sfero Döküm / Ductile Iron (T-1445)
	3	Volan / Handwheel	GG 25 - EN GJL 250 - Pik Döküm / Cast Iron
	4	Mil / Stem	X20Cr13 - AISI420 - Paslanmaz Çelik / Stainless Steel
	5	Sürgü / Wedge	GGG 40 - EN GJS 400-15 - Sfero Döküm + Kauçuk Kaplı / Ductile Iron + Rubber Coated
	6	Conta / Gasket	EPDM - NBR

Ölçüler / Dimensions	Anma Basıncı / Nominal Pressure	16 Bar										
	Anma Çapı / Nominal Diameter	DN	40	50	65	80	100	125	150	200	250	300
	Vana Boyutları / Valve Dimensions	L	240	250	270	280	300	325	350	400	450	500
		H	170	180	230	245	265	355	400	490	615	700
		W	160				200	250		315		
		D	150	165	185	200	220	250	285	340	405	460
		k	110	125	145	160	180	210	240	295	355	410
		g	84	99	118	132	156	184	211	266	319	370
		b	18	20		22	24	26		30	32	
		dxn	19x4			19x8			23x8	23x12	28x12	
Ağırlık / Weight	Kg	12	13	20	22	30	48	59	104	160	216	

T-1410 Pik Döküm / Cast Iron

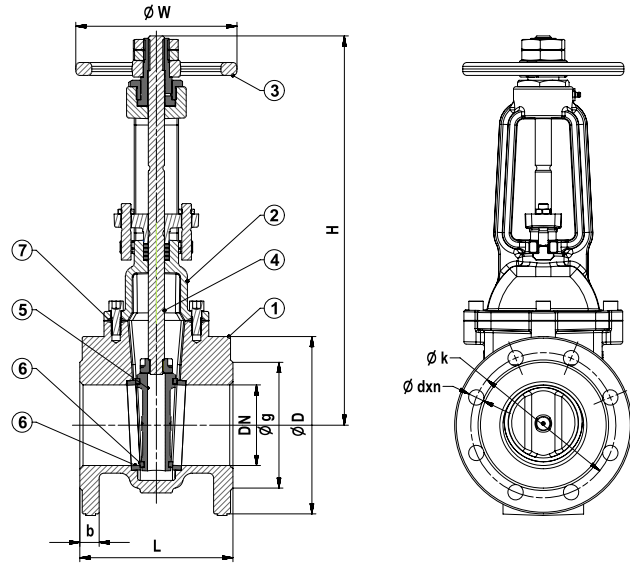

Genel Özellikler / General Specifications

Çalışma Sıcaklık Aralığı / Working Temperature : -10 ... +120 °C
(2,5 / 4 / 10 / 16 Bar)

Standartlar / Standards

Sertifikalar / Certificates :

Tasarım / Design : TS EN 1171

Flans Boyutları / Flange Dimensions : TS EN 1092-2 (PN 10)

Alından Alına Boyutları / Face to Face Dimensions : TS EN 558 (Seri 14)

Testler / Tests : TS EN 12266-1

Uygulamalar / Applications

Sıcak ve soğuk su sistemleri, gemi sanayi, yangın tesisatlarında
Hot and cold water systems, marine industry, fire fighting systems

Malzeme Özellikleri / Material Specifications	No	Parça Adı / Part Name	Malzeme / Material
	1	Gövde / Body	GG 25 - EN GJL 250 - Pik Döküm / Cast Iron
	2	Kapak / Bonnet	GG 25 - EN GJL 250 - Pik Döküm / Cast Iron
	3	Volan / Handwheel	GG 25 - EN GJL 250 - Pik Döküm / Cast Iron
	4	Mil / Stem	X20Cr13 - AISI420 - Paslanmaz Çelik / Stainless Steel
	5	Sürgü / Wedge	GG 25 - EN GJL 250 - Pik Döküm / Cast Iron
	6	Sitler / Seats	CuZn40Pb2 - CW617N - Pirinç - Paslanmaz Çelik - Bronz / Brass - Stainless Steel - Bronze
	7	Conta / Gasket	EPDM - NBR

Ölçüler / Dimensions	Anma Basıncı / Nominal Pressure	16 Bar								10 Bar				4 Bar		2,5 Bar
	Anma Çapı / Nominal Diameter	DN	40	50	65	80	100	125	150	200	250	300	350	400	500	600
	Vana Boyutları / Valve Dimensions	L	140	150	170	180	190	200	210	230	250	270	290	310	350	390
		H min	355	365	390	425	485	584	655	796	970	1110	1280	1400	1550	1940
		H max	405	430	475	525	605	735	835	1020	1245	1440	1660	1830	2100	2590
		W	200				250				315		400		500	
		D	150	165	185	200	220	250	285	340	395	445	505	565	670	780
		k	110	125	145	160	180	210	240	295	350	400	460	515	620	725
		g	84	99	118	132	156	184	211	266	319	370	429	480	582	682
		b	18	20		22	24	26			28		30	32	34	36
dxn		19x4				19x8				23x8		23x12		23x16	28x16	28x20
Ağırlık / Weight	Kg	11	15	20	24	30	44	58	106	158	232	295	420	560	780	

T-1370 Pik Döküm / Cast Iron

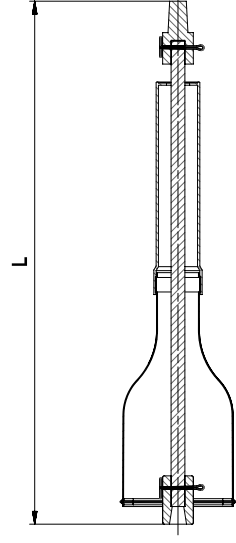
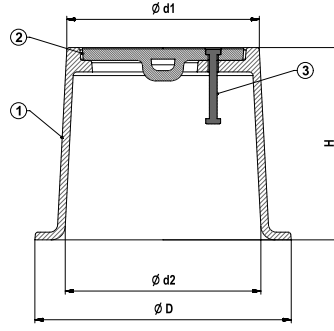

Malzeme Özellikleri / Material Specifications	No	Parça Adı / Part Name	Malzeme / Material
	1	Kazan / Surface Box	GG 25 - EN GJL 250 - Pik Döküm / Cast Iron
	2	Kapak / Bonnet	GG 25 - EN GJL 250 - Pik Döküm / Cast Iron
	3	Pim / Pin	St37 - Çelik / Steel

Ölçüler / Dimensions	16 Bar					
	Tip / Type	d1	d2	D	H	L
	TİP 1 (DN 40-300)	150	150	200	150	600

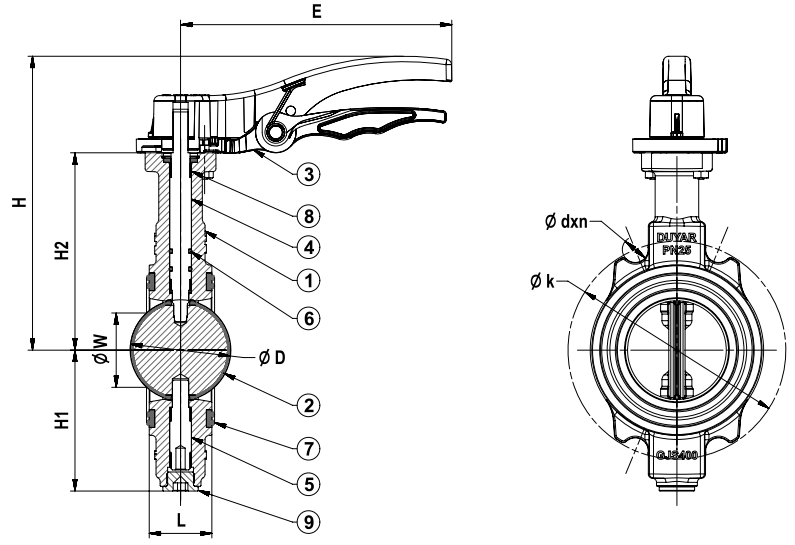

Genel Özellikler / General Specifications

Çalışma Sıcaklık Aralığı / Working Temperature : -10 ... +110 °C (25 Bar)

Standartlar / Standards

Sertifikalar / Certificates :

Tasarım / Design : TS EN 593

Bağlantı Boyutları / Connection Dimensions : TS EN 1092-2 (PN 25)

Testler / Tests : TS EN 12266-1

Uygulamalar / Applications

HVAC sistemleri, arıtma tesisleri, kağıt endüstrisi, tatlı su tesisatları, deniz suyu HVAC systems, water treatment systems, paper industry, fresh water system, sea water

No	Parça Adı / Part Name	Malzeme / Material
1	Gövde / Body	GGG 40 - EN GJS 400-15 - Sfero Döküm / Ductile Iron
2	Klape + Kaplama / Clapper + Plated	GGG 40 - EN GJS 400-15 - Sfero Döküm + Kauçuk Kaplama / Ductile Iron + Rubber Coated
3	Kol / Lever	Alüminyum Enjeksiyon / Aluminum Injection
4	Üst Mil / Top Stem	X20Cr13 - AISI420 - Paslanmaz Çelik / Stainless Steel
5	Alt Mil / Bottom Stem	X20Cr13 - AISI420 - Paslanmaz Çelik / Stainless Steel
6	O-Ring	EPDM
7	Alın Contası / Face Gasket	EPDM
8	Mil Yatağı / Stem Bearing	Paslanmaz Çelik + Bronz / Stainless Steel + Bronze
9	Tapa / Plug	St 37 - Çelik / Steel

Ölçüler / Dimensions	Anma Basıncı / Nominal Pressure		25 Bar						
	Anma Çapı / Nominal Diameter	DN	65	80	100	125	150	200	
Vana Boyutları / Valve Dimensions	L		46		52		56	60	
	E		210			265		355	
	H1		93	103	113	135	149	175	
	H2		135	145	152	175	185	222	
	H		205	235	242	245	275	305	
	W		41.5	58	84	107	135	186	
	D		62	74	98.5	121.0	146	196	
	k		145	160	190	220	250	310	
	dxn			19x8		23x8		28x8	28x12
	Tepe Flanş / Upper Flange			(ISO 5211) F05			(ISO 5211) F07		(ISO 5211) F10
Mil Karesi / Stem Square			□11		□14		□17		
Ağırlık / Weight	Kg		3,8	4,5	7,2	10,5	13	20,4	

KAUÇUK KAPLI WAFER KELEBEK VANA (PN 16)

-RUBBER COATED WAFER BUTTERFLY VALVE (PN 16)



T-1135 Pik Döküm / Cast Iron

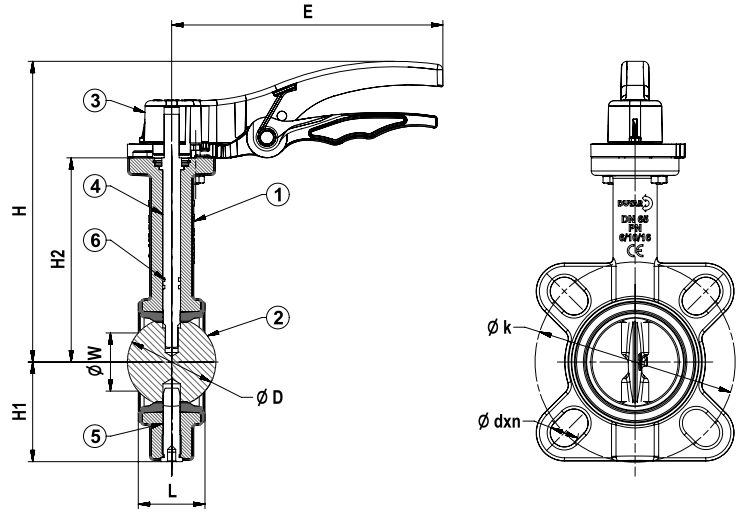

Genel Özellikler / General Specifications

Çalışma Sıcaklık Aralığı / Working Temperature : -10 ... +110 °C (16 Bar)

Standartlar / Standards

Sertifikalar / Certificates :  

Tasarım / Design : TS EN 593

Bağlantı Boyutları / Connection Dimensions : TS EN 1092-2 (PN 16)

Testler / Tests : TS EN 12266-1

Uygulamalar / Applications

HVAC sistemleri, arıtma tesisleri, kağıt endüstrisi, tatlı su tesisatları, deniz suyu HVAC systems, water treatment systems, paper industry, fresh water system, sea water

No	Parça Adı / Part Name	Malzeme / Material
1	Gövde / Body	GG 25 - EN GJL 250 - Pik Döküm + Kauçuk Kaplama / Cast Iron + Rubber Coated
2	Klape + Kaplama / Clapper + Plated	GGG 40 - EN GJS 400 -15 - Sfero Döküm + Nikel Kaplama - GX6CrNi189 - CF8-Paslanmaz Çelik / Ductile Iron + Nickel Plated - Cast Stainless Steel
3	Kol / Lever	Alüminyum Enjeksiyon / Aluminum Injection
4	Üst Mil / Top Stem	X20Cr13 - AISI420 - Paslanmaz Çelik / Stainless Steel
5	Alt Mil / Bottom Stem	X20Cr13 - AISI420 - Paslanmaz Çelik / Stainless Steel
6	O-Ring	EPDM

Ölçüler / Dimensions	Anma Basıncı / Nominal Pressure	16 Bar								
	Anma Çapı / Nominal Diameter	DN	40	50	65	80	100	125	150	200
	Vana Boyutları / Valve Dimensions	L	33	43	46		52	56		60
		E	210				265			355
		H1	65	70	73	96	107	128	140	170
		H2	130	140	150	160	182	196	200	240
		H	200	210	220	230	250	265	285	325
		W	26.8	31	45.9	62.2	90.6	110	145.6	193.9
		D	42.5	53	65	79	104.5	123.5	156	203
		k	110	125	145	160	180	210	240	295
dxn		19x4			19x8			23x8	23x12	
Tepe Flanş / Upper Flange		(ISO 5211) F05				(ISO 5211) F07			(ISO 5211) F10	
Mil Karesi / Stem Square	□9				□14	□17				
Ağırlık / Weight	Kg	2,5	3	3,5	4	6	7,5	10	14,5	

T-0910 Sfero Döküm / Ductile Iron

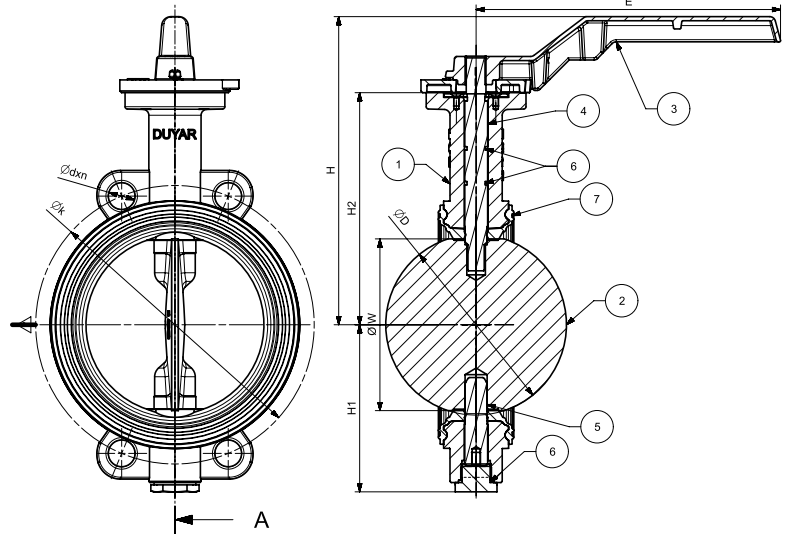

Genel Özellikler / General Specifications

Çalışma Sıcaklık Aralığı / Working Temperature : -10 ... +110 °C (16 Bar)

Standartlar / Standards

Sertifikalar / Certificates :

Tasarım / Design : TS EN 593

Bağlantı Boyutları / Connection Dimensions : TS EN 1092-2

DN40-DN150: PN10/16 - DN200-DN450: PN16

Testler / Tests : TS EN 12266-1

Uygulamalar / Applications

HVAC Sistemleri, Arıtma Tesisleri, Kağıt Endüstrisi, Tatlı Su Tesisatları

HVAC Systems, Water treatment systems, Paper industry, Fresh water system

No	Parça Adı / Part Name	Malzeme / Material
1	Gövde / Body	GGG 40 - EN GJS 400-15 - Sfero Döküm / Ductile Iron
2	Klape + Kaplama / Clapper + Plated	GGG 40 - EN GJS 400-15 - Sfero Döküm + Nikel Kaplama / Ductile Iron + Nickel Plated
3	Kol / Lever	GGG 40 - EN GJS 400-15 - Sfero Döküm / Ductile Iron
4	Üst Mil / Top Stem	X20Cr13 - AISI420 - Paslanmaz Çelik / Stainless Steel
5	Alt Mil / Bottom Stem	X20Cr13 - AISI420 - Paslanmaz Çelik / Stainless Steel
6	O-Ring	EPDM
7	Vulkanize Conta / Seat	EPDM - NBR

Anma Basıncı / Nominal Pressure	16 Bar																	
	Anma Çapı / Nominal Diameter	DN	40	50	65	80	100	125	150	200	250	300	350	400	450	500*	600*	
Vana Boyutları / Valve Dimensions	L	33	43	46	52	56	60	68	78	102	114	127	154	Dişli Kutuludur / With Gear Box				
	E	210			265			355			Dişli Kutuludur / With Gear Box							
	H1	77	81	87	99	111	132	144	185	208	251	277	308	342	374	459		
	H2	144	162	175	193	200	218	226	280	315	354	388	416	455	490	562		
	H	205	222	235	253	260	288	296	340	Dişli Kutuludur / With Gear Box								
	W	26,8	31	45,9	62,2	90,6	110	145,6	193,9	241,6	292,3	341,8	388,8	445,6	480,5	566,4		
	D	42,5	53	65	79	104,5	123,5	156	203	251	302,5	354	402	455	492,5	582		
	k	110	125	145	160	180	210	240	295	355	410	470	525	585	650	770		
	dxn	19x4			19x8			23x8	23x12	28x12		28x16	31x16	31x20	34x20	37x20		
	Tepe Flanş / Upper Flange	F05				F07				F10				F16				
Mil Ölçüsü / Stem Dimension	□9				□14				□17				□22		□27		Ø41,3	Ø50,8
Ağırlık / Weight	Kg	2,5	3	3,5	4	6	7	9	15	23	27	49	90	110	150	242		

*DN500 ve DN600 ölçüleri sitli model olup, PN 6/10/16 flanş bağlantısına uygundur.

/*DN500 and DN600 are produced with seat and are suitable with PN 6/10/16 flange connections.

WAFER VULKANİZE KELEBEK VANA (PASLANMAZ KLAPELİ, PN 16)

-WAFER VULCANIZED BUTTERFLY VALVE (STAINLESS STEEL CLAPPER, PN 16)



T-0930 Sfero Döküm / Ductile Iron

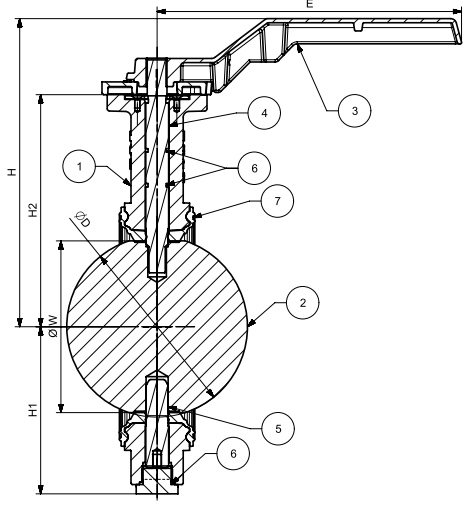
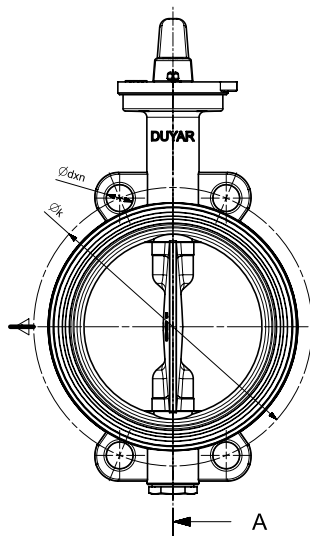

Genel Özellikler / General Specifications
Çalışma Sıcaklık Aralığı / Working Temperature : -10 ... +110 °C (16 Bar)

Standartlar / Standards
Sertifikalar / Certificates :

Tasarım / Design : TS EN 593
Bağlantı Boyutları / Connection Dimensions : TS EN 1092-2
DN40-DN150: PN10/16 - DN200-DN450: PN16
Testler / Tests : TS EN 12266-1

Uygulamalar / Applications
HVAC Sistemleri, Arıtma Tesisleri, Kağıt Endüstrisi, Tatlı Su Tesisatları
HVAC Systems, Water treatment systems, Paper industry, Fresh water system

No	Parça Adı / Part Name	Malzeme / Material
1	Gövde / Body	GGG 40 - EN GJS 400-15 - Sfero Döküm / Ductile Iron
2	Klape / Clapper	G-X6CrNi189 - CF8 - Paslanmaz Çelik / Cast Stainless Steel
3	Kol / Lever	GGG 40 - EN GJS 400-15 - Sfero Döküm / Ductile Iron
4	Üst Mil / Top Stem	X20Cr13 - AISI420 - Paslanmaz Çelik / Stainless Steel
5	Alt Mil / Bottom Stem	X20Cr13 - AISI420 - Paslanmaz Çelik / Stainless Steel
6	O-Ring	EPDM
7	Vulkanize Conta / Seat	EPDM - NBR

Anma Basıncı / Nominal Pressure	16 Bar																
	Anma Çapı / Nominal Diameter	DN	40	50	65	80	100	125	150	200	250	300	350	400	450	500*	600*
Ölçüler / Dimensions	L	33	43	46		52	56		60	68	78		102	114	127	154	
	E	210			265			355			Dişli Kutuludur / With Gear Box						
	H1	77	81	87	99	111	132	144	185	208	251	277	308	342	374	459	
	H2	144	162	175	193	200	218	226	280	315	354	388	416	455	490	562	
	H	205	222	235	253	260	288	296	340	Dişli Kutuludur / With Gear Box							
	W	26.8	31	45.9	62.2	90.6	110	145.6	193.9	241.6	292.3	341.8	388.8	445.6	480.5	566.4	
	D	42.5	53	65	79	104.5	123.5	156	203	251	302.5	354	402	455	492.5	582	
	k	110	125	145	160	180	210	240	295	355	410	470	525	585	650	770	
	dxn	19x4			19x8			23x8	23x12	28x12		28x16	31x16	31x20	34x20	37x20	
	Tepe Flanş / Upper Flange	F05			F07			F10			F16						
Mil Ölçüsü / Stem Dimension	□9			□14			□17			□22			□27				
Ağırlık / Weight	Kg	2,5	3	3,5	4	6	7	9	15	23	27	49	90	110	150	242	

*DN500 ve DN600 ölçüleri sitli model olup, PN 6/ 10 / 16 flanş bağlantısına uygundur.
/*DN500 and DN600 are produced with seat and are suitable with PN 6/10/16 flange connections.

T-1010 Sfero Döküm / Ductile Iron

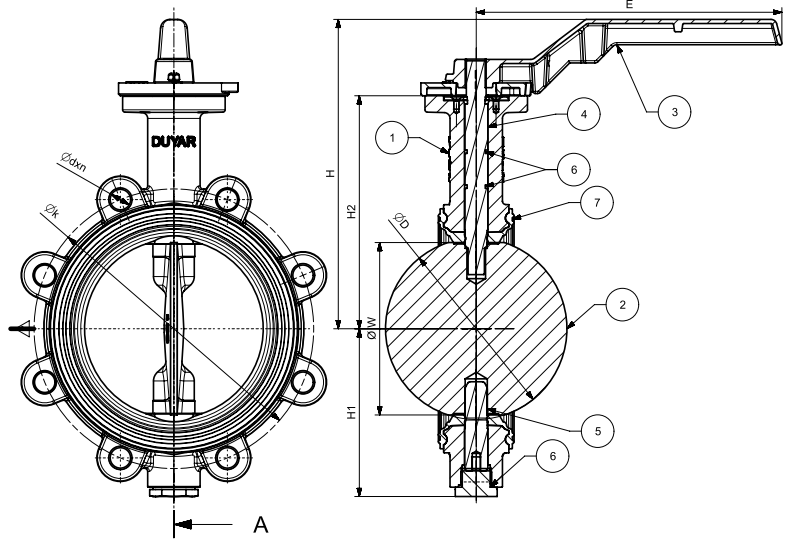

Genel Özellikler / General Specifications

Çalışma Sıcaklık Aralığı / Working Temperature : -10 ... +110 °C (16 Bar)

Standartlar / Standards

Sertifikalar / Certificates :

Tasarım / Design : TS EN 593

Bağlantı Boyutları / Connection Dimensions : TS EN 1092-2

DN40-DN150: PN10/16 - DN200-DN450: PN16

Testler / Tests : TS EN 12266-1

Uygulamalar / Applications

HVAC Sistemleri, Arıtma Tesisleri, Kağıt Endüstrisi, Tatlı Su Tesisatları

HVAC Systems, Water treatment systems, Paper industry, Fresh water system

No	Parça Adı / Part Name	Malzeme / Material
1	Gövde / Body	GGG 40 - EN GJS 400-15 - Sfero Döküm / Ductile Iron
2	Klape + Kaplama / Clapper + Plated	GGG 40 - EN GJS 400-15 - Sfero Döküm + Nikel Kaplama / Ductile Iron + Nickel Plated
3	Kol / Lever	GGG 40 - EN GJS 400-15 - Sfero Döküm / Ductile Iron
4	Üst Mil / Top Stem	X20Cr13 - AISI420 - Paslanmaz Çelik / Stainless Steel
5	Alt Mil / Bottom Stem	X20Cr13 - AISI420 - Paslanmaz Çelik / Stainless Steel
6	O-Ring	EPDM
7	Vulkanize Conta / Seat	EPDM - NBR

Anma Basıncı / Nominal Pressure	16 Bar																			
	Anma Çapı / Nominal Diameter	DN	40	50	65	80	100	125	150	200	250	300	350	400	450	500*	600*			
Vana Boyutları / Valve Dimensions	L	33	43	46	52	56	60	68	78	102	114	127	154	Dişli Kutuludur / With Gear Box						
	E	210			265			355			Dişli Kutuludur / With Gear Box									
	H1	77	81	87	99	111	132	144	185	208	251	277	308	342	374	459				
	H2	144	162	175	193	200	218	226	280	315	354	388	416	455	490	562				
	H	205	222	235	253	260	288	296	340	Dişli Kutuludur / With Gear Box										
	W	26,8	31	45,9	62,2	90,6	110	145,6	193,9	241,6	292,3	341,8	388,8	445,6	480,5	566,4				
	D	42,5	53	65	79	104,5	123,5	156	203	251	302,5	354	402	455	492,5	582				
	k	110	125	145	160	180	210	240	295	355	410	470	525	585	650	770				
	dxn	M16x4			M16x8			M20x8	M20x12	M24x12	M24x16	M27x16	M27x20	M30x20	M33x20					
	Tepe Flanş / Upper Flange	F05				F07				F10				F16						
Mil Ölçüsü / Stem Dimension	□9				□14				□17				□22				□27		Ø41,3	Ø50,8
Ağırlık / Weight	Kg	2,5	3	3,5	4	6	7	9	15	23	27	49	90	110	159	250				

*DN500 ve DN600 ölçüleri sitli model olup, PN 6/ 10 / 16 flanş bağlantısına uygundur.
/*DN500 and DN600 are produced with seat and are suitable with PN 6/10 / 16 flange connections.

LUG VULKANİZE KELEBEK VANA (PASLANMAZ KLAPELİ, PN16)

-LUG VULCANIZED BUTTERFLY VALVE (STAINLESS STEEL CLAPPER, PN 16)



T-1030 Sfero Döküm / Ductile Iron

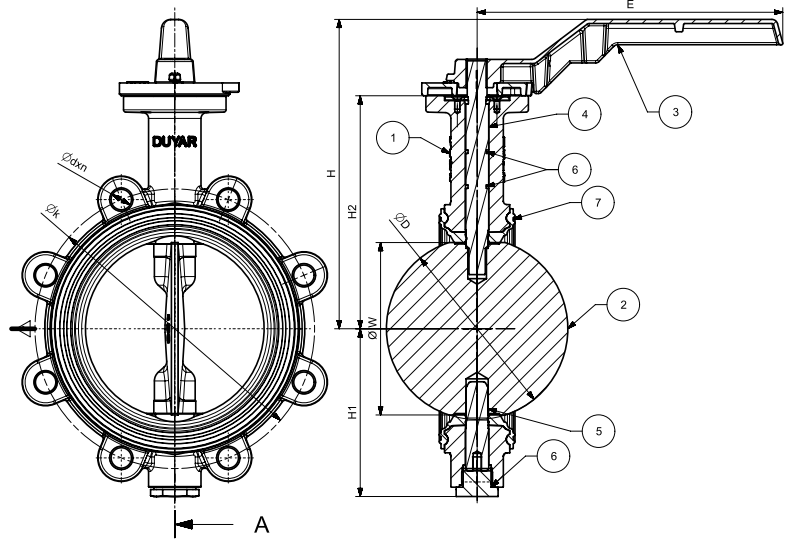

Genel Özellikler / General Specifications

Çalışma Sıcaklık Aralığı / Working Temperature : -10 ... +110 °C (16 Bar)

Standartlar / Standards

Sertifikalar / Certificates :

Tasarım / Design : TS EN 593

Bağlantı Boyutları / Connection Dimensions : TS EN 1092-2

DN40-DN150: PN10/16 - DN200-DN450: PN16

Testler / Tests : TS EN 12266-1

Uygulamalar / Applications

HVAC Sistemleri, Arıtma Tesisleri, Kağıt Endüstrisi, Tatlı Su Tesisatları

HVAC Systems, Water treatment systems, Paper industry, Fresh water system

No	Parça Adı / Part Name	Malzeme / Material
1	Gövde / Body	GGG 40 - EN GJS 400-15 - Sfero Döküm / Ductile Iron
2	Klape / Clapper	G-X6CrNi189 - CF8 - Paslanmaz Çelik / Cast Stainless Steel
3	Kol / Lever	GGG 40 - EN GJS 400-15 - Sfero Döküm / Ductile Iron
4	Üst Mil / Top Stem	X20Cr13 - AISI420 - Paslanmaz Çelik / Stainless Steel
5	Alt Mil / Bottom Stem	X20Cr13 - AISI420 - Paslanmaz Çelik / Stainless Steel
6	O-Ring	EPDM
7	Vulkanize Conta / Seat	EPDM - NBR

Anma Basıncı / Nominal Pressure	16 Bar																					
	DN	40	50	65	80	100	125	150	200	250	300	350	400	450	500*	600*						
Anma Çapı / Nominal Diameter	L	33	43	46	52	56	60	68	78	102	114	127	154									
	E	210			265			355	Dişli Kutuludur / With Gear Box													
	H1	77	81	87	99	111	132	144	185	208	251	277	308	342	374	459						
	H2	144	162	175	193	200	218	226	280	315	354	388	416	455	490	562						
	H	205	222	235	253	260	288	296	340	Dişli Kutuludur / With Gear Box												
	W	26.8	31	45.9	62.2	90.6	110	145.6	193.9	241.6	292.3	341.8	388.8	445.6	480.5	566.4						
	D	42.5	53	65	79	104.5	123.5	156	203	251	302.5	354	402	455	492.5	582						
	k	110	125	145	160	180	210	240	295	355	410	470	525	585	650	770						
	dxn	M16x4			M16x8			M20x8	M20x12	M24x12	M24x16	M27x16	M27x20	M30x20	M33x20							
	Tepe Flanş / Upper Flange	F05				F07				F10				F16								
Mil Ölçüsü / Stem Dimension	□9				□14				□17				□22				□27		Ø41,3		Ø50,8	
Ağırlık / Weight	Kg	2,5	3	3,5	4	6	7	9	15	23	27	49	90	110	159	250						

*DN500 ve DN600 ölçüleri sitli model olup, PN 6/ 10 / 16 flanş bağlantısına uygundur.

/*DN500 and DN600 are produced with seat and are suitable with PN 6/10 / 16 flange connections.

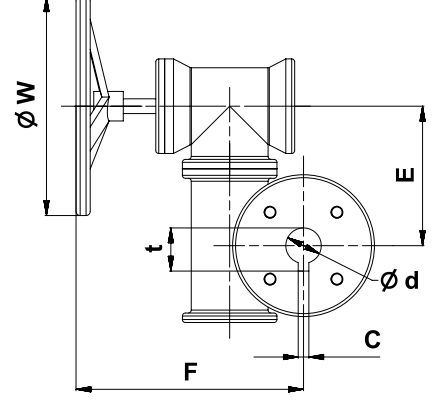
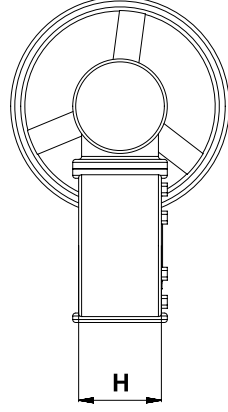

Vana Ölçüsü / Valve Size		Tork / Torque Nm	Tahvil Oranı / Ratio	W	E	H	F	□A / Ød	C	t	Tepe Flanşı / Upper Flange	Ağırlık / Weight (Kg.)
DN mm	NPS mm											
40	1 1/2"	170	24:1	150	50	62	150	□9	-	-	(ISO 5211) F05	4.5
50	2"											
65	2 1/2"											
80	3"											
100	4"	750	30:1	300	70	80	220	□14	-	-	(ISO 5211) F07	7.5
125	5"											
150	6"											
200	8"											
250	10"	1200	50:1	360	95	105	217	□22	8	35.1	(ISO 5211) F10	14
300	12"											
350	14"											
400	16"											
450	18"	2500	80:1	360	185	120	210	□27	10	41.4	(ISO 5211) F16	65
500	20"											
500	20"											
600	24"											
600	24"	4000	416:1					Ø41,3		44.6		72
600	24"							Ø50,8	16	55.1		

T-0110 Pik Döküm / Cast Iron
T-0120 Sfero Döküm / Ductile Iron

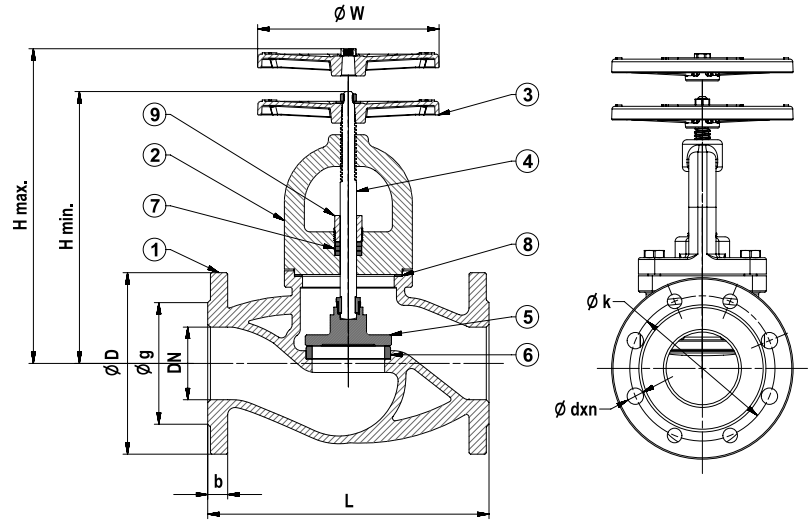

Genel Özellikler / General Specifications

Çalışma Sıcaklık Aralığı / Working Temperature : -10 ... +120 °C (16 Bar),
200 °C (13 Bar), 250 °C (11 Bar), 300 °C (10 Bar)

Standartlar / Standards

Sertifikalar / Certificates : CE

Tasarım / Design : TS EN 13789

Flanş Boyutları / Flange Dimensions : TS EN 1092-2 (PN 16)

Alından Alına Boyutlar / Face to Face Dimensions : TS EN 558 (Seri 1)

Testler / Tests : TS EN 12266-1

Uygulamalar / Applications

Sıcak ve soğuk su sistemleri, deniz suyu (sfero döküm), basınçlı hava, kızgın su, buhar, kızgın buhar, asit ve alkali özelliği bulunmayan sıvı akışkanlar

Hot and cold water systems, sea water (Ductile Iron), compressed air, superheated water, steam, superheated steam systems, non-acidic and non-flammable liquid fluids

Malzeme Özellikleri / Material Specifications	No	Parça Adı / Part Name	Malzeme / Material
	1	Gövde / Body	GG 25 - EN GJL 250 - Pik Döküm / Cast Iron (T-0110) GGG 40 - EN GJS 400-15 - Sfero Döküm / Ductile Iron (T-0120)
	2	Kapak / Bonnet	GG 25 - EN GJL 250 - Pik Döküm / Cast Iron (T-0110) GGG 40 - EN GJS 400-15 - Sfero Döküm / Ductile Iron (T-0120)
	3	Volan / Handwheel	GG 25 - EN GJL 250 - Pik Döküm / Cast Iron (T-0110 T-0120)
	4	Mil / Stem	X20Cr13 - AISI420 - Paslanmaz Çelik / Stainless Steel DN 15-100, X20Cr13 - AISI420 - Paslanmaz Çelik / Stainless Steel
	5	Klape / Disc	DN 125-300, St 37 - Çelik + Paslanmaz Çelik / Steel + Stainless Steel
	6	Sit / Seat	X5CrNi18 10 - AISI304 - Paslanmaz Çelik / Stainless Steel
	7	Salmastra / Packing	Grafit / Graphite
	8	Conta / Gasket	Grafit / Graphite
9	Salmastra Baskısı / Packing gland	CuZn40Pb2 - CW617N - Pirinç Dövme / Forced Brass	

Ölçüler / Dimensions	Anma Basıncı / Nominal Pressure	16 Bar														10 Bar				
	Anma Çapı / Nominal Diameter	DN	15	20	25	32	40	50	65	80	100	125	150	200	250	300				
	Vana Boyutları / Valve Dimensions	L	130	150	160	180	200	230	290	310	350	400	480	600	730	850				
		H min.	185	190	215	220	235	245	265	290	310	365	425	570	730	860				
		H max.	200		230	240	275	310		345	395	455	535	680	800	870				
		W	125				160			200		250	315		400	500				
		D	95	105	115	140	150	165	185	200	220	250	285	340	405	460				
		k	65	75	85	100	110	125	145	160	180	210	240	295	355	410				
		g	46	56	65	76	84	99	118	132	156	184	211	266	319	370				
		b	14	16		18			20		22	24		30		32				
dxn	14x4				19x4				19x8			23x8	23x12	28x12						
Ağırlık / Weight	Kg	4	5	6	8	10	14	21	29	42	63	89	155	259	357					

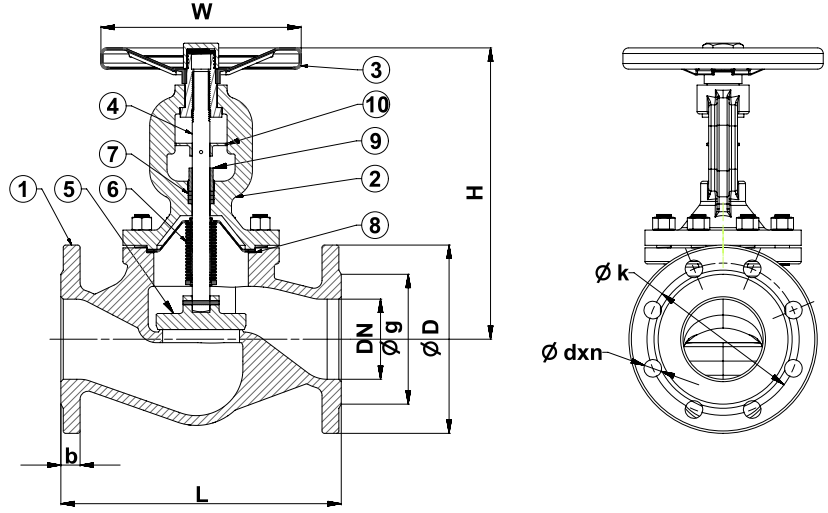

Genel Özellikler / General Specifications

Çalışma Sıcaklık Aralığı / Working Temperature : -20 ... +400°C (40 Bar),
150°C (35,2 Bar), 250°C (30,4 Bar), 300°C (26,7 Bar), 350°C (25,7 Bar),
400°C (23,8 Bar)

Standartlar / Standards

Sertifikalar / Certificates :

Tasarım / Design : TS EN 13789

Flans Boyutları / Flange Dimensions : TS EN 1092-1 (PN 40)

Alından Alına Boyutlar / Face to Face Dimensions : TS EN 558 (Seri 1)

Testler / Tests : TS EN 12266-1

Uygulamalar / Applications

Sıcak ve soğuk su sistemleri, deniz suyu, basınçlı hava, kızgın su, buhar, kızgın buhar, asit ve alkali özelliği bulunmayan sıvı akışkanlar
Hot and cold water systems, sea water, compressed air, superheated water, steam, superheated steam systems, non-acidic and non-flammable liquid fluids

No	Parça Adı / Part Name	Malzeme / Material
1	Gövde / Body	GSC 25 - GP240GH - Çelik Döküm / Cast Steel
2	Kapak / Bonnet	GSC 25 - GP240GH - Çelik Döküm / Cast Steel
3	Volan / Handwheel	St37 - Çelik / Steel
4	Mil / Stem	X5CrNi18 10 - AISI304 - Paslanmaz Çelik / Stainless Steel
5	Klape / Disc	X5CrNi18 10 - AISI304 - Paslanmaz Çelik / Stainless Steel
6	Körük / Bellows	X5CrNi18 10 - AISI304 - Paslanmaz Çelik / Stainless Steel
7	Salmastra / Packing	Esnek Grafit Conta / Flexible Graphite Gasket
8	Conta / Gasket	Esnek Grafit Conta + Paslanmaz Çelik / Flexible Graphite Gasket + Stainless Steel
9	Salmastra Baskısı / Packing Gland	CuZn40Pb2 - CW617N - Pirinç Dövme / Forced Brass
10	Seviye Göstergesi / Level Indicator	St37 - Çelik / Steel

Anma Basıncı / Nominal Pressure	40 Bar															
	DN	15	20	25	32	40	50	65	80	100	125	150	200	250	300	
Anma Çapı / Nominal Diameter	L	130	150	160	180	200	230	290	310	350	400	480	600	730	850	
	H	190	195	210	220	230	255	270	360	380	415	530	665	720		
	W	140	160	180	200	250	280	300	350	400	450	500				
	D	95	105	115	140	150	165	185	200	235	270	300	375	450	515	
	k	65	75	85	100	110	125	145	160	190	220	250	320	385	450	
	g	45	58	68	78	88	102	122	138	162	188	218	285	345	410	
	b	16	18	20	22	24	26	28	34	38	42					
	dxn	14x4	18x4	18x8	22x8	26x8	30x12	33x12	33x16							
Ağırlık / Weight	Kg.	4	4,5	5	8	10	13,5	20	25	45	60	98	171	340	580	

METAL KÖRÜKLÜ GLOB VANA (PN 16)

-METAL BELLOWS SEALED GLOBE VALVE (PN 16)



T-0160 Çelik Döküm / Cast Steel

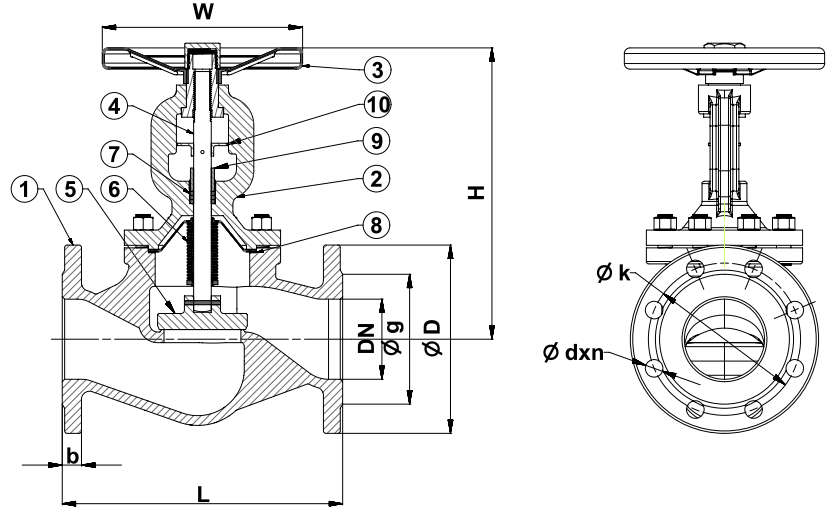

Genel Özellikler / General Specifications

Çalışma Sıcaklık Aralığı / Working Temperature : -20 ... +400 °C (16 Bar)

Standartlar / Standards

Sertifikalar / Certificates :

Tasarım / Design : TS EN 13789

Flanş Boyutları / Flange Dimensions : TS EN 1092-1 (PN 16)

Alından Alına Boyutlar / Face to Face Dimensions : TS EN 558 (Seri 1)

Testler / Tests : TS EN 12266-1

Uygulamalar / Applications

Sıcak ve soğuk su sistemleri, deniz suyu, basınçlı hava, kızgın su, buhar, kızgın buhar, asit ve alkali özelliği bulunmayan sıvı akışkanlar
Hot and cold water systems, sea water, compressed air, superheated water, steam, superheated steam systems, non-acidic and non-flammable liquid fluids

No	Parça Adı / Part Name	Malzeme / Material
1	Gövde / Body	G5-C 25 - GP240GH - Çelik Döküm / Steel Iron
2	Kapak / Bonnet	G5-C 25 - GP240GH - Çelik Dökü / Steel Iron
3	Volan / Handwheel	Sı37 - Çelik / Steel
4	Mil / Stem	X5CrNi18 10 - AISI304 - Paslanmaz Çelik / Stainless Steel
5	Klape / Disc	X5CrNi18 10 - AISI304 - Paslanmaz Çelik / Stainless Steel
6	Körük / Bellows	X5CrNi18 10 - AISI304 - Paslanmaz Çelik / Stainless Steel
7	Salmastra / Packing	Esnek Grafit Cont / Flexible Graphite Gasket
8	Conta / Gasket	Esnek Grafit Conta + Paslanmaz Çelik / Flexible Graphite Gasket + Stainless Steel
9	Salmastra Baskısı / Packing gland	CuZn40Pb2 - CW617N - Pirinç Dövme / Forced Brass
10	Seviye Göstergesi / Level Indicator	Sı37 - Çelik / Steel

Anma Basıncı / Nominal Pressure	16 Bar									
	DN	65	80	100	125	150	200	250	300	
Vana Boyutları / Valve Dimensions	L	290	310	350	400	480	600	730	850	
	H	255	270	360	380	415	530	665	720	
	W		250	280	300	350	400	450	500	
	D	185	200	220	250	285	340	405	460	
	k	145	160	180	210	240	295	355	410	
	g	122	138	158	188	212	268	320	378	
	b	18	20		22		24	26	28	
	dxn	18x4		18x8		22x8	22x12		26x12	
Ağırlık / Weight	Kg.	20	25	45	60	98	171	340	580	

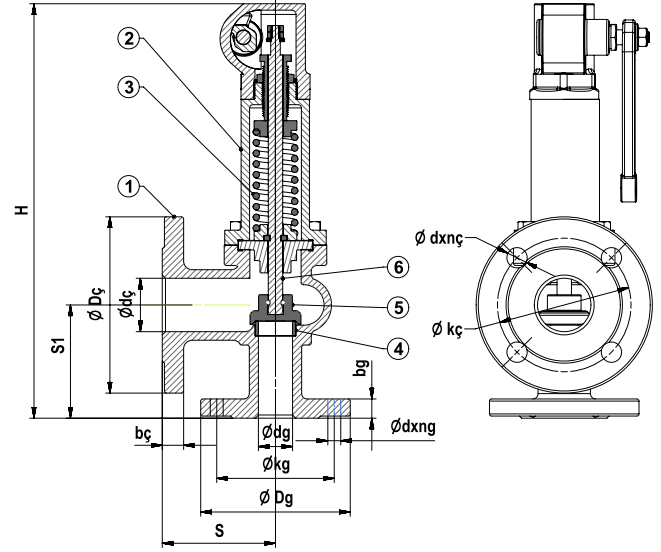

Genel Özellikler / General Specifications

Çalışma Sıcaklık Aralığı / Working Temperature : -10 ... +120 °C (16 Bar),
200 °C (13 Bar), 250 °C (11 Bar), 300 °C (10 Bar)

Standartlar / Standards

Sertifikalar / Certificates :

Tasarım / Design : TS EN ISO 4126

Flanş Boyutları / Flange Dimensions : TS EN 1092-2 (PN 16)

Alından Alına Boyutlar / Face to Face Dimensions : TS EN 558 (Seri 8)

Testler / Tests : TS EN 12266-1

Uygulamalar / Applications

Doymuş buhar sistemleri
Saturated steam applications

Malzeme Özellikleri / Material Specifications	No	Parça Adı / Part Name	Malzeme / Material
	1	Gövde / Body	GGG 40 - EN GJS 400-15 - Sfero Döküm / Ductile Iron
	2	Kapak / Bonnet	GGG 40 - EN GJS 400-15 - Sfero Döküm / Ductile Iron
	3	Yay / Spring	X12CrNi18 8 - AISI302 - Paslanmaz Çelik / Stainless Steel
	4	Sit / Seat	X5CrNi18-10 - AISI304 - Paslanmaz Çelik / Stainless Steel
	5	Klape / Disc	X5CrNi18-10 - AISI304 - Paslanmaz Çelik / Stainless Steel
	6	Mil / Stem	X5CrNi18-10 - AISI304 - Paslanmaz Çelik / Stainless Steel

Ölçüler / Dimensions	Anma Basıncı / Nominal Pressure	16 Bar							
	Anma Çapı / Nominal Diameter	DN	25 / 40	32 / 50	40 / 65	50 / 80	65 / 100	80 / 125	100 / 150
	Vana Boyutları / Valve Dimensions	S	100	110	115	120	140	160	180
		S1	105	115	140	150	170	195	220
		H	410	435	470	490	580	755	860
		Dg	115	140	150	165	185	200	220
		Dç	150	165	185	200	220	250	285
		dg	25	32	40	50	65	80	100
		dç	40	50	65	80	100	125	150
		kg	85	100	110	125	145	160	180
		kç	110	125	145	160	180	210	240
		bg	16	18	20	22	24	26	28
	bç	18	20	22	24	26	28	30	
	dxng	14x4	19x4	19x4	19x4	19x8	19x8	23x8	
dxnç	19x4	19x4	19x4	19x8	19x8	23x8	23x8		
Ağırlık / Weight	Kg	13	16	18	21	33	50	70	

ORANSAL KALKIŞLI EMNİYET VENTİLİ (YAYLI, PN 16)

-PROPORTIONAL LIFT SAFETY VALVE (WITH SPRING, PN 16)



T-1510 Pik Döküm / Cast Iron
T-1515 Sfero Döküm / Ductile Iron

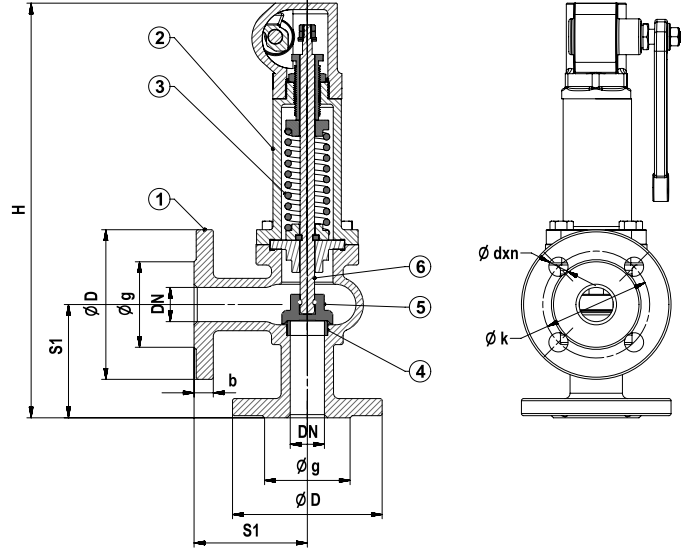

Genel Özellikler / General Specifications

Çalışma Sıcaklık Aralığı / Working Temperature : -10 ... +120 °C (16 Bar),
200 °C (13 Bar), 250 °C (11 Bar), 300 °C (10 Bar)

Standartlar / Standards

Sertifikalar / Certificates :

Tasarım / Design : TS EN ISO 4126

Flanş Boyutları / Flange Dimensions : TS EN 1092-2 (PN 16)

Alından Alına Boyutlar / Face to Face Dimensions : TS EN 558 (Seri 8)

Testler / Tests : TS EN 12266-1

Uygulamalar / Applications

Sıcak ve soğuk su sistemleri, asit ve alkali özelliği bulunmayan sıvı akışkanlar
Hot and cold water systems, non-acidic and non-flammable liquid fluids

Malzeme Özellikleri / Material Specifications	No	Parça Adı / Part Name	Malzeme / Material
	1	Gövde / Body	GG 25 - EN GJL 250 - Pik Döküm / Cast Iron (T-1510) GGG 40 - EN GJS 400-15 - Sfero Döküm / Ductile Iron (T-1515)
2	Kapak / Bonnet	GG 25 - EN GJL 250 - Pik Döküm / Cast Iron (T-1510) GGG 40 - EN GJS 400-15 - Sfero Döküm / Ductile Iron (T-1515)	
3	Yay / Spring	X12CrNi18 8 - AISI 302 - Paslanmaz Çelik / Stainless Steel	
4	Sit / Seat	X5CrNi18 10 - AISI304 - Paslanmaz Çelik / Stainless Steel	
5	Klape / Disc	X5CrNi18 10 - AISI304 - Paslanmaz Çelik / Stainless Steel	
6	Mil / Stem	X5CrNi18 10 - AISI304 - Paslanmaz Çelik / Stainless Steel	

Ölçüler / Dimensions	Anma Basıncı / Nominal Pressure	16 Bar							
	Anma Çapı / Nominal Diameter	DN	25	32	40	50	65	80	100
Vana Boyutları / Valve Dimensions	S1	100	105	115	125	145	155	175	
	H	383	402	413	430	519	584	636	
	D	115	140	150	165	185	200	220	
	k	85	100	110	125	145	160	180	
	g	65	76	84	99	118	132	156	
	b	16	18		20		22	24	
	dxn	14x4	19x4				19x8		
Ağırlık / Weight	Kg	9,8	11,7	13,8	17	26,5	30	48	

T-1610 Pik Döküm (Flanşlı) / Cast Iron (Flanged)
T-1620 Pik Döküm (Dişli) / Cast Iron (Threaded)

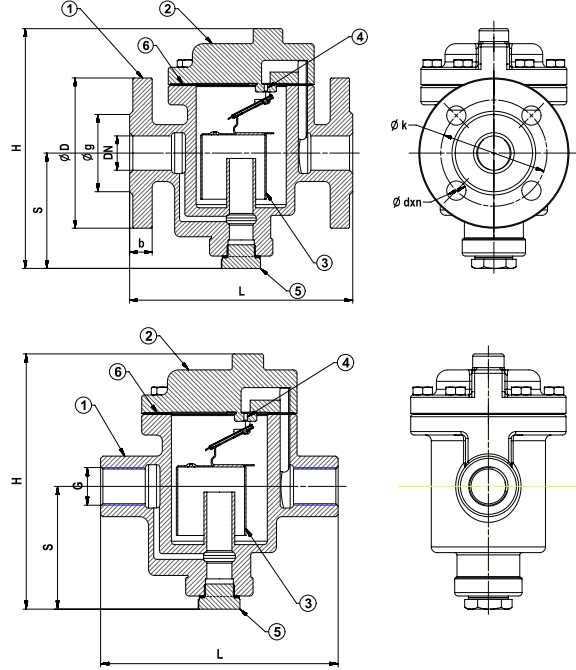

Genel Özellikler / General Specifications

Çalışma Sıcaklık Aralığı / Working Temperature : -10 ... +120 °C (16 Bar),
200 °C (13 Bar), 250 °C (11 Bar), 300 °C (10 Bar)

Standartlar / Standards

Sertifikalar / Certificates :

Tasarım / Design : TS EN ISO 4126

Flanş Boyutları / Flange Dimensions : TS EN 1092-2 (PN 16)

Diş Standartı / Thread Standard : EN ISO 228-1

Testler / Tests : TS EN 12266-1

Uygulamalar / Applications

Doymuş buhar sistemleri
Saturated steam applications

Malzeme Özellikleri / Material Specifications	No	Parça Adı / Part Name	Malzeme / Material	
			T-1610	T-1620
	1	Gövde / Body	GG 25 - EN GJL 250 - Pik Döküm / Cast Iron	GG 25 - EN GJL 250 - Pik Döküm / Cast Iron
	2	Kapak / Bonnet	GG 25 - EN GJL 250 - Pik Döküm / Cast Iron	GG 25 - EN GJL 250 - Pik Döküm / Cast Iron
	3	Kova / Bucket	X5CrNi18 10 - AISI304 - Paslanmaz Çelik / Stainless Steel	X5CrNi18 10 - AISI304 - Paslanmaz Çelik / Stainless Steel
	4	Orifis / Orifice	X5CrNi18 10 - AISI304 - Paslanmaz Çelik / Stainless Steel	X5CrNi18 10 - AISI304 - Paslanmaz Çelik / Stainless Steel
	5	Tapa / Plug	St37 - Çelik / Steel	St37 - Çelik / Steel
	6	Conta / Gasket	Klingerit	

Ters Kovalı Kondenstop Flanşlı Ölçüler / Inverted Bucket Steam Trap Flanged Dimensions	Anma Basıncı / Nominal Pressure		16 Bar						
	Anma Çapı / Nominal Diameter		DN	15	20	25	32	40	50
	Vana Boyutları / Valve Dimensions		L	170	180	195	205	245	280
			H	170	180	190	200	235	275
			S	90	95	100	105	120	130
			D	95	105	115	140	150	165
			k	65	75	85	100	110	125
			g	46	56	65	76	84	99
			b	14	16		18		20
			dxn	14x4			19x4		20
Ağırlık / Weight		Kg	5,5	6,4	8,1	9,9	15,8	24,9	

Ters Kovalı Kondenstop Dişli Ölçüler / Inverted Bucket Steam Trap Threaded Dimensions	Anma Basıncı / Nominal Pressure		16 Bar						
	Anma Çapı / Nominal Diameter		DN	15	20	25	32	40	50
	Vana Boyutları / Valve Dimensions		G	1 / 2"	3 / 4"	1"	1 1 / 4"	1 1 / 2"	2"
			L	140	150	170	180	220	245
			H	170	180	190	200	235	275
			S	90	95	100	105	120	130
	Ağırlık / Weight		Kg	4,9	6	7,5	7,9	13,4	22,1



YERLİ ÜRETİM GÜCÜ



444⁸²⁶²
VANA

DuyarValve.Com DuyarVana.Com.Tr



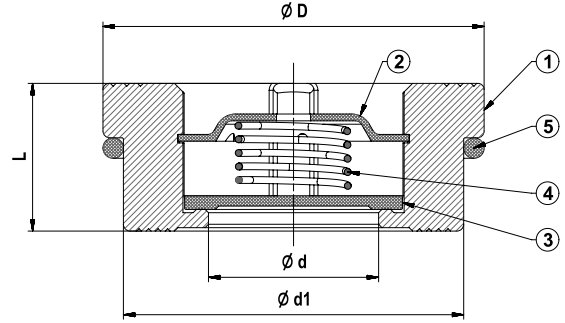

Genel Özellikler / General Specifications

Çalışma Sıcaklık Aralığı / Working Temperature : -10 ... +120 °C (16 Bar)

Standartlar / Standards

Sertifikalar / Certificates : CE P16

Tasarım / Design : TS 10873

Flans Boyutları / Flange Dimensions : TS EN 1092-2 (PN 16)

Alından Alına Boyutlar / Face to Face Dimensions : TS EN 558 (Seri 49)

Testler / Tests : TS EN 12266-1

Uygulamalar / Applications

Sıcak ve soğuk su sistemleri, basınçlı hava, asit ve alkali özelliği bulunmayan sıvı akışkanlar, sıvı yakıt sistemleri
Hot and cold water systems, compressed air, non-acidic and non-flammable liquid fluids, liquid fuel systems

No	Parça Adı / Part Name	Malzeme / Material
1	Gövde / Body	CuZn40Pb2 - CW617N - Pirinç / Brass
2	Klavuz / Disc Guide	X5CrNi18 10 - AISI304 - Paslanmaz Çelik / Stainless Steel
3	Klape / Disc	X5CrNi18 10 - AISI304 - Paslanmaz Çelik / Stainless Steel
4	Yay / Spring	X12CrNi18 8 - AISI302 - Paslanmaz Çelik / Stainless Steel
5	Montaj Yayısı / Mounting Spring	X12CrNi18 8 - AISI302 - Paslanmaz Çelik / Stainless Steel

Ölçüler / Dimensions	Anma Basıncı / Nominal Pressure	16 Bar									
	Anma Çapı / Nominal Diameter	DN	15	20	25	32	40	50	65	80	100
	Vana Boyutları / Valve Dimensions	$\varnothing d$	15	20	25	31.5	39	48	64	74	89
		L	16	19	22	28	31.5	40	46	50	60
		D	40	47	56	72	82	95	115	132	152
$\varnothing d1$		36	44	51	67	78	90	108	126	146	
Ağırlık / Weight	Kg	0.094	0.134	0.202	0.458	0.620	0,976	1,360	2,078	3,030	

Min. Açma Basıncı (mBar) / Min. Opening Pressure		Disk Tip Çek Vana / Disc Type Check valve										
		Anma Çapı / Nominal Diameter	DN	15	20	25	32	40	50	65	80	100
Akış Yönü / Flow Direction	Yaylı / With Spring	→	21									
		←	17	18.3	16.3	16.2	16.1	15	13.7	12.5		
	Yaysız / Without Spring	→	23					24	25		26	26.5
		←	2.6	3.9	4	4.2	5.1	5.6	7.4			

DISK TİP ÇEK VANA SFERO DÖKÜM (PN 16)

-DISC TYPE CHECK VALVE DUCTILE IRON (PN 16)



T-0320 Sfero Döküm / Ductile Iron

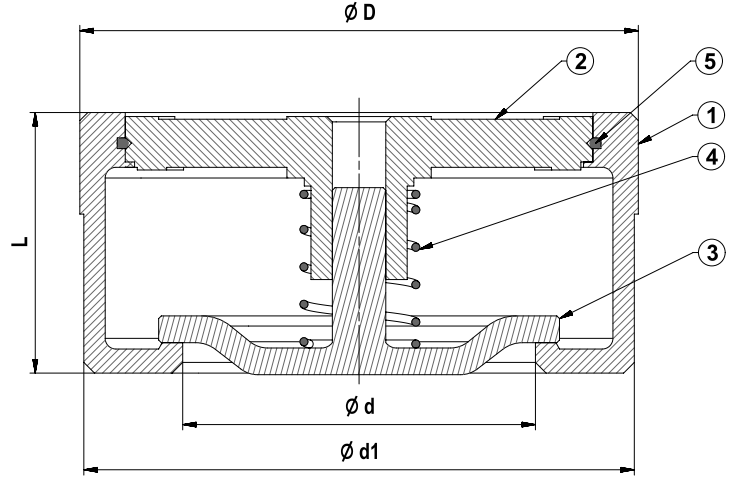

Genel Özellikler / General Specifications

Çalışma Sıcaklık Aralığı / Working Temperature : -10 ... +120 °C (16 Bar),
200 °C (13 Bar), 250 °C (11 Bar), 300 °C (10 Bar)

Standartlar / Standards

Sertifikalar / Certificates :

Tasarım / Design : TS EN 12334

Flanş Boyutları / Flange Dimensions : TS EN 1092-2 (PN 16)

Alından Alına Boyutlar / Face to Face Dimensions : TS EN 558 (Seri 49)

Testler / Tests : TS EN 12266-1

Uygulamalar / Applications

Sıcak ve soğuk su sistemleri, basınçlı hava, asit ve alkali özelliği bulunmayan sıvı akışkanlar, sıvı yakıt sistemleri
Hot and cold water systems, compressed air, non-acidic and non-flammable liquid fluids, liquid fuel systems

No	Parça Adı / Part Name	Malzeme / Material
1	Gövde / Body	GGG 40 - EN GJS 400-15 - Sfero Döküm / Ductile Iron
2	Klavuz / Disc Guide	GGG 40 - EN GJS 400-15 - Sfero Döküm / Ductile Iron
3	Klape / Disc	GGG 40 - EN GJS 400-15 - Sfero Döküm / Ductile Iron
4	Yay / Spring	X12CrNi18 8 - AISI302 - Paslanmaz Çelik / Stainless Steel
5	Segman / Piston Ring	X12CrNi18 8 - AISI302 - Paslanmaz Çelik / Stainless Steel

Ölçüler / Dimensions	Anma Basıncı / Nominal Pressure	16 Bar								
	Anma Çapı / Nominal Diameter	DN	40	50	65	80	100	125	150	200
	Vana Boyutları / Valve Dimensions	Ød	39	48	64	74	89	112	132	175
		L	31.5	40	46	50	60	90	106	140
		D	82	95	115	132	152	184	209	264
Ød1		78	90	108	126	146	181	206	260	
Ağırlık / Weight	Kg	0.620	0.976	1.360	2.078	3.030	6,800	10.000	20,000	

Min. Açma Basıncı (mBar) / Min. Opening Pressure	Disk Tip Çek Vana										
	Anma Çapı / Nominal Diameter	DN	40	50	65	80	100	125	150	200	
	Akış Yönü / Flow Direction	Yaylı / With Spring	→	21					22	23.5	24
			←	16.2	16.1	15	13.7	12.5	12	13	14.5
	Yaysız / Without Spring	→	24	25			26	26.5	30	32.5	35
←		4	4.2	5.1	5.6	7.4	15	17	18.5		

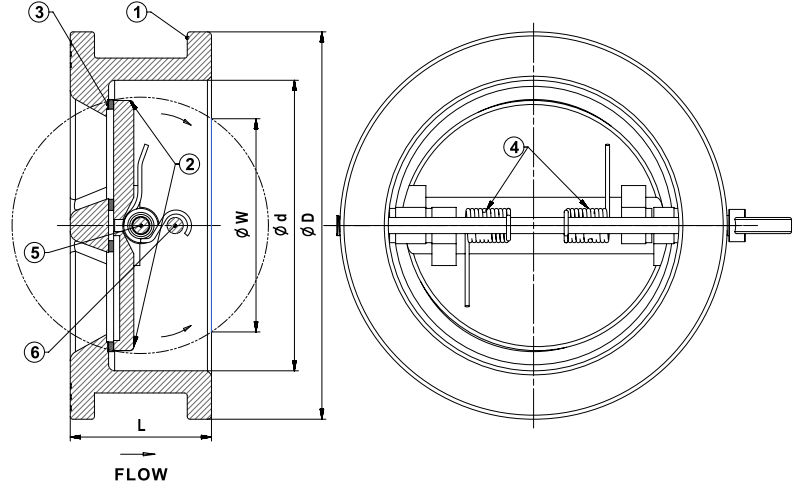

Genel Özellikler / General Specifications

Çalışma Sıcaklık Aralığı / Working Temperature : -10 ... +120 °C (16 Bar)

Standartlar / Standards

Sertifikalar / Certificates :

Tasarım / Design : TS EN 12334

Flanş Boyutları / Flange Dimensions : TS EN 1092-2 (PN 16)

Testler / Tests : TS EN 12266-1

Uygulamalar / Applications

Sulama sistemleri, Arıtma sistemleri ve pis su hatları, Yangın tesisatları, Yağ devreleri
Hot and water systems, Irrigation and water supply lines, Purification systems and waste water discharge, Fire projection lines, Oil-cooling cycles

Malzeme Özellikleri / Material Specifications	No	Parça Adı / Part Name	Malzeme / Material
	1	Gövde / Body	GG 25 - EN GJL 250 - Pik Döküm / Cast Iron
	2	Klape / Disc	GGG 40 - EN GJS 400-15 - Sfero Döküm / Ductile Iron
	3	Sit / Seat	EPDM - NBR
	4	Yay / Spring	X12CrNi18 8 - AISI302 - Paslanmaz Çelik / Stainless Steel
	5	Mil / Stem	X20Cr13 - AISI420 - Paslanmaz Çelik / Stainless Steel
	6	Stop Pimi / Stop Pin	X20Cr13 - AISI420 - Paslanmaz Çelik / Stainless Steel

Ölçüler / Dimensions	Anma Basıncı / Nominal Pressure	16 Bar													
	Anma Çapı / Nominal Diameter	DN	50	65	80	100	125	150	200	250	300	350	400	500	600
	Vana Boyutları / Valve Dimensions	ØD	107	127	142	162	192	218	273	328	378	438	489	594	695
		Ød	65	80	94	117	145	170	224	265	310	360	410	505	625
		L	43	46	64		70	76	89	114		127	140	152	177
Ağırlık / Weight	Kg	1,3	1,6	2,8	4	5,5	8	13.5	24.4	33	46.4	62	103.4	125	

YAYLI ÇEK VANA (PN 16) -CHECK VALVE (WITH SPRING PN 16)



T-0250 Pik Döküm / Cast Iron
T-0260 Sfero Döküm / Ductile Iron

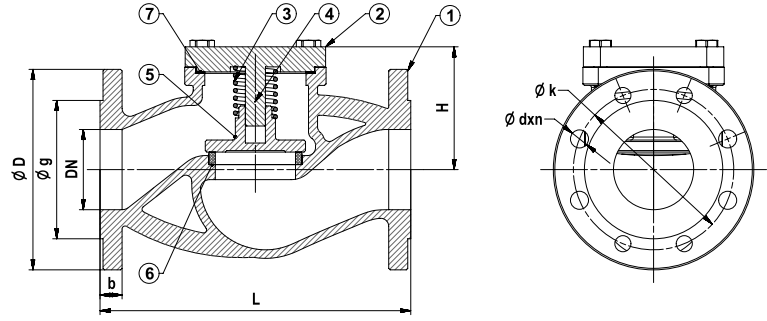

Genel Özellikler / General Specifications

Çalışma Sıcaklık Aralığı / Working Temperature : -10 ... +120 °C (16 Bar),
200 °C (13 Bar), 250 °C (11 Bar), 300 °C (10 Bar)

Standartlar / Standards

Sertifikalar / Certificates :

Tasarım / Design : TS EN 12334

Flanş Boyutları / Flange Dimensions : TS EN 1092-2 (PN 16)

Alından Alına Boyutlar / Face to Face Dimensions : TS EN 558 (Seri 1)

Testler / Tests : TS EN 12266-1

Uygulamalar / Applications

Sıcak ve soğuk su sistemleri, basınçlı hava, kızgın su, buhar, kızgın buhar, asit ve alkali özelliği bulunmayan sıvı akışkanlar
Hot and cold water systems, compressed air, superheated water, steam, superheated steam systems, non-acidic and non-flammable liquid fluids

Malzeme Özellikleri / Material Specifications	No	Parça Adı / Part Name	Malzeme / Material
	1	Gövde / Body	GG 25 - EN GJL 250 - Pik Döküm / Cast Iron (T-0250) GGG 40 - EN GJS 400-15 - Sfero Döküm / Ductile Iron (T-0260)
	2	Kapak / Bonnet	GG 25 - EN GJL 250 - Pik Döküm / Cast Iron (T-0250) GGG 40 - EN GJS 400-15 - Sfero Döküm / Ductile Iron (T-0260)
	3	Yay / Spring	X12CrNi18 8 - AISI302 - Paslanmaz Çelik / Stainless Steel
	4	Mil / Stem	DN 15-100, GG 25 - EN GJL 250 - Pik Döküm / Cast Iron DN 125-300, X20Cr13 - AISI420 - Paslanmaz Çelik / Stainless Steel
	5	Klape / Disc	DN 15-80, X20Cr13 - AISI420 - Paslanmaz Çelik / Stainless Steel DN 100-300, St 37 - Çelik + Paslanmaz Çelik / Steel + Stainless Steel
	6	Sit / Seat	X5CrNi18 10 - AISI304 - Paslanmaz Çelik / Stainless Steel
	7	Conta / Gasket	Klingerit

Ölçüler / Dimensions	Anma Basıncı / Nominal Pressure	16 Bar												10 Bar			
	Anma Çapı / Nominal Diameter	DN	15	20	25	32	40	50	65	80	100	125	150	200	250	300	
	Vana Boyutları / Valve Dimensions	L	130	150	160	180	200	230	290	310	350	400	480	600	730	850	
		Min. Strok	5		6	8	10	13	16	20	25	32	40	50	63	75	
		H	60	62	65	70	90	95	115	135	145	165	195	238	258	315	
		D	95	105	115	140	150	165	185	200	220	250	285	340	405	460	
		k	65	75	85	100	110	125	145	160	180	210	240	295	355	410	
		g	46	56	65	76	84	99	118	132	156	184	211	266	319	370	
		b	14	16		18			20		22	24	26		30	32	
		d _{xn}	14x4			19x4				19x8			23x8	23x12	28x12		
Ağırlık / Weight	Kg	3	3.5	4.4	5.8	7.9	11.4	15.8	23.5	36	55	71	122	215	325		

T-0410 Pik Döküm / Cast Iron
T-0420 Sfero Döküm / Ductile Iron

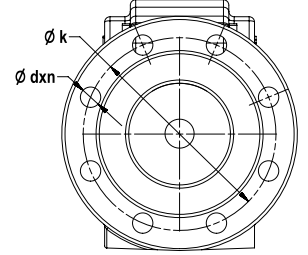
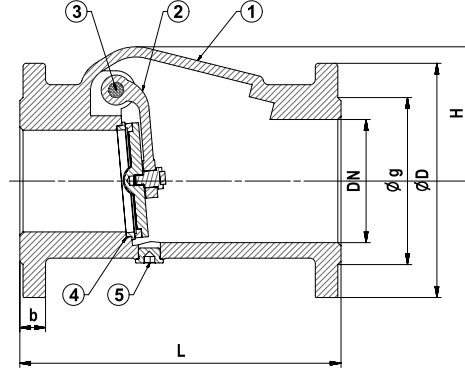

Genel Özellikler / General Specifications

Çalışma Sıcaklık Aralığı / Working Temperature : -10 ... +120 °C (16 Bar)

Standartlar / Standards

Sertifikalar / Certificates :

Tasarım / Design : TS EN 12334

Flanş Boyutları / Flange Dimensions : TS EN 1092-2 (PN 16)

Alından Alına Boyutlar / Face to Face Dimensions : TS EN 558 (Seri 48)

Testler / Tests : TS EN 12266-1

Uygulamalar / Applications

Sıcak ve soğuk su sistemleri, asitlik olmayan tüm akışkanlarda
Hot and cold water, all non acidic fluids

Malzeme Özellikleri / Material Specifications	No	Parça Adı / Part Name	Malzeme / Material
	1	Gövde / Body	GG 25 - EN GJL 250 - Pik Döküm / Cast Iron (T-0410) DN 40-150 GGG 40 - EN GJS 400-15 - Sfero Döküm / Ductile Iron (T-0420)
	2	Klape / Disc	GGG 40 - EN GJS 400-15 - Sfero Döküm + Kauçuk Kaplama / Ductile Iron + Rubber Coated
	3	Mil / Stem	X20Cr13 - AISI420 - Paslanmaz Çelik / Stainless Steel
	4	Sitler / Seats	CuZn40Pb2 - CW617N - Pirinç - Paslanmaz Çelik - Bronz / Brass - Stainless Steel - Bronze
5	Tapa / Plug	Sf37 - Çelik / Steel	

* Sit sadece DN 300 ve DN 350 anma çaplarında mevcuttur.

* The seat is only for diameters DN 300 & DN 350

Ölçüler / Dimensions	Anma Basıncı / Nominal Pressure	16 Bar											
	Anma Çapı / Nominal Diameter	DN	40	50	65	80	100	125	150	200	250	300	350
Vana Boyutları / Valve Dimensions	L	180	200	240	260	300	350	400	500	600	700	800	
	H	70		87	104	125	157	186	240	295	372	375	
	D	150	165	185	200	220	250	285	340	405	460	520	
	k	110	125	145	160	180	210	240	295	355	410	470	
	g	84	99	118	132	156	184	211	266	319	370	420	
	b	18	20		22	24	26		20	22	25	36	
	dxn	19x4			19x8			23x8	23x12	28x12		28x16	
Ağırlık / Weight	Kg	6	7.5	10,5	14	20	30	43	70	120	164	215	

WAFER ÇALPARA ÇEK VALF (PN 16)

-WAFER SWING CHECK VALVE (PN 16)



T-0430 Karbon Çelik Döküm / Cast Carbon Steel

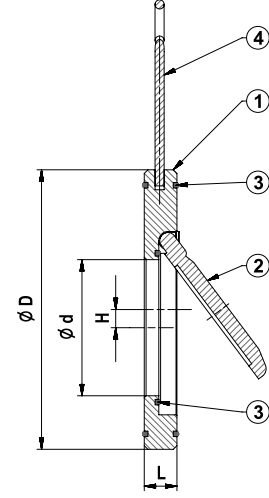
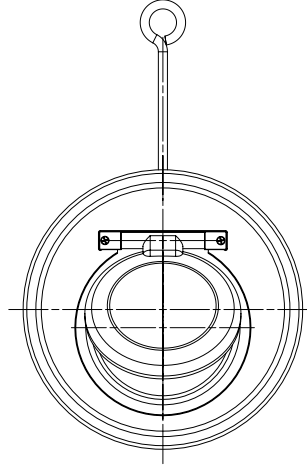

Genel Özellikler / General Specifications

Çalışma Sıcaklık Aralığı / Working Temperature : -10 ... +120 °C (16 Bar)

Standartlar / Standards

Sertifikalar / Certificates : CE

Flanş Boyutları / Flange Dimensions : TS EN 1092-2 (PN 16)

Testler / Tests : TS EN 12266-1

Uygulamalar / Applications

Deniz suyu (paslanmaz çelik), kondens sistemleri (paslanmaz çelik), arıtma sistemleri, HVAC sistemleri
Sea water (stainless steel), condensation systems (stainless steel), purification systems, HVAC systems

Malzeme Özellikleri / Material Specifications	No	Parça Adı / Part Name	Malzeme / Material
			1
2	Klape / Disc	GS-C 25 - GP240GH Karbon Çelik Döküm + Nikel Kaplama / Cast Carbon Steel + Nickel Plated (T-0430) - Cast Stainless Steel (T-0450)	
3	O-Ring / O-Ring	EPDM - NBR	
4	Mapa / Eye Bolt	St 37 - Çelik + Nikel Kaplama / Steel + Nickel Plated	

Ölçüler / Dimensions	16 Bar															
	Anma Basıncı / Nominal Pressure															
Anma Çapı / Nominal Diameter	DN	40	50	65	80	100	125	150	200	250	300	350	400	500	600	
Vana Boyutları / Valve Dimensions	ØD	92	107	127	142	162	192	218	273	329	384	444	491	610	724	
	Ød	22	32	40	54	70	92	114	154	200	235	280	316	405	486	
	L	14			18			20	22	26	28	38	44	56	62	
	H	0		2	3	4	5	6	8	9	10	11	12	13	15	
Ağırlık / Weight	Kg	0,7	0,8	1,2	1,5	2,3	3,5	4,1	7	12	18	22	25	30	40	

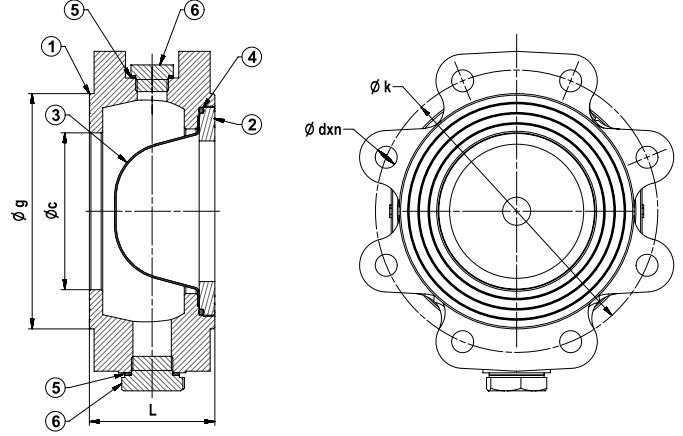

Genel Özellikler / General Specifications

Çalışma Sıcaklık Aralığı / Working Temperature : -10 ... +120 °C (16 Bar)

Standartlar / Standards

Sertifikalar / Certificates : CE PG

Bağlantı Boyutları / Connection Dimensions : TS EN 1092-2 (PN 16)

Testler / Tests : TS EN 12266-1

Uygulamalar / Applications

Sıcak ve soğuk su sistemleri, basınçlı hava, asit ve alkali özelliği bulunmayan sıvı akışkanlar
Hot and cold water systems, compressed air, non-acidic and non-flammable liquid fluids

Malzeme Özellikleri / Material Specifications	No	Parça Adı / Part Name	Malzeme / Material
	1	Gövde / Body	GGG 40 - EN GJS 400-15 - Sfero Döküm / Ductile Iron
	2	Kapak / Bonnet	GGG 40 - EN GJS 400-15 - Sfero Döküm / Ductile Iron
	3	Filtre / Filter	AISI304 L - Paslanmaz Çelik / Stainless Steel
	4	O-Ring	EPDM
	5	Tapa Contası / Plug Gasket	Bakır / Copper
6	Tapa / Plug	St37 - Çelik / Steel	

Ölçüler / Dimensions	Anma Basıncı / Nominal Pressure	16 Bar													
	Anma Çapı / Nominal Diameter	DN	40	50	65	80	100	125	150	200	250	300	350	400	
Vana Boyutları / Valve Dimensions	L		50		65		80	100	125	150	200	250	300	350	
	D		84	99	118	132	150	184	208	266	319	370	429	481	
	c		40	50	65	80	100	125	150	200	250	300	350	400	
	k		110	125	145	160	180	210	240	295	355	410	470	525	
	dxn		M16x4			M16x8			M20x8	M20x12	M24x12		M24x16	M27x16	
Ağırlık / Weight	Kg		2.5	3	3,8	5.2	6.6	9.8	14.7	23,5	38,6	56,6	82,2	106,4	
Filtre / Filter	Kalınlık (mm) / Thickness (mm)		1						1,5			2			

Y TIPI PİSLİK TUTUCU (PN 16) -Y TYPE STRAINER (PN 16)



T-0820 Pik Döküm / Cast Iron
T-0830 Sfero Döküm / Ductile Iron

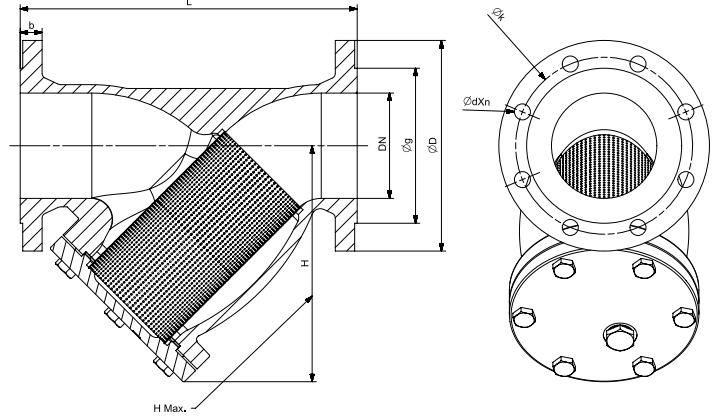

Genel Özellikler / General Specifications

Çalışma Sıcaklık Aralığı / Working Temperature : -10 ... +120 °C (16 Bar),
200 °C (13 Bar), 250 °C (11 Bar), 300 °C (10 Bar)

Standartlar / Standards

Sertifikalar / Certificates :

Tasarım / Design : TS 11494

Flanş Boyutları / Flange Dimensions : TS EN 1092-2 (PN 16)

Alından Alına Boyutlar / Face to Face Dimensions : TS EN 558 (Seri 1)

Testler / Tests : TS EN 12266-1

Uygulamalar / Applications

Sıcak ve soğuk su sistemleri, basınçlı hava, doymuş buhar, asit ve alkali özelliği bulunmayan sıvı akışkanlar

Hot and cold water systems, compressed air, saturated steam, non-acidic and non-flammable liquid fluids

No	Parça Adı / Part Name	Malzeme / Material
1	Gövde / Body	GG 25 - EN GJL 250 - Pik Döküm / Cast Iron (T0820) DN 15-300 GGG 40 - EN GJS 400-15 - Sfero Döküm / Ductile Iron (T0830)
2	Kapak / Bonet	GG 25 - EN GJL 250 - Pik Döküm / Cast Iron (T0820) DN 15-300 GGG 40 - EN GJS 400-15 - Sfero Döküm / Ductile Iron (T0830)
3	Filtre / Filter	X5CrNi18 10 - AISI304 - Paslanmaz Çelik / Stainless Steel
4	Takviye Sacı / Reinforcing Frame (DN 50-800)	Paslanmaz Çelik / Stainless Steel
5	Conta / Gasket	Grafit / Graphite
6	Tapa Contası / Plug Gasket (DN 50-800)	Bakır / Copper
8	Tapa / Plug (DN 50-800)	St37

Anma Basıncı / Nominal Pressure Anma Çapı / Nominal Diameter	16 Bar																				
	DN	15	20	25	32	40	50	65	80	100	125	150	200	250	300	350	400	500	600	700	800
Ölçüler / Dimensions Vana Boyutları / Valve Dimensions	L	130	150	160	180	200	230	290	310	350	400	480	600	730	850	980	1100	1250	1450	1650	1850
	H	65	78	88	126	135	145	165	175	236	267	298	340	390	440	520	630	900	1100	1300	1750
	H max.	117	140	160	203	232	260	333	363	454	510	579	657	875	960	1160	1329	1750	2000	2350	2950
	D	95	105	115	140	150	165	185	200	220	250	285	340	405	460	520	580	715	840	910	1025
	k	65	75	85	100	110	125	145	160	180	210	240	295	355	410	470	525	650	770	840	950
	g	46	56	65	76	84	99	118	132	156	184	211	266	319	370	429	480	609	720	794	901
	b	14	16	18	20	22	24	26	30	32	26.5	28	31.5	36	39.5	43					
	dxn	14x4	19x4	19x8	23x8	23x12	28x12	28x16	31x16	34x20	37x20	37x24	41x24								
Ağırlık / Weight	Kg	2	3	4	6.5	7.5	10,5	16	21,5	28,5	39	52,5	89,5	149	240	350	429	610	735	870	980

Sac Kalınlığı / Sheet Thickness	0.8 mm																0.5 mm		0.8 mm		1.0 mm		1.5 mm		2.0 mm	
	DN	15	20	25	32	40	50	65	80	100	125	150	200	250	300	350	400	500	600	700	800					
Filtre / Filter	Ød	23±0,5	28±0,5	36±0,5	42±0,5	46±0,5	55±0,5	78±0,5	87±0,5	109±1	135±1	160±1	210±1	258±1	308±1	365±1	410±1									
	L	56±0,5	68±0,5	82±0,5	98±0,5	96±0,5	98±0,5	132±0,5	149±0,5	192±1,5	227±1,5	244±1,5	313±1,5	394±1,5	434±2	630±2	645±2									
	Açıklımı	75±0,5	90±0,5	116±0,5	145±0,5	150±1	180±2	251±2	287±2	348±2	430±2	506±2	666±3	832±3	983±3	1162±3	1303±3									
Delik Çapı / Hole Diameter	30 MESH □0,6										2 mm		2 mm		4 mm		5 mm		6 mm							
Delik Aralığı / Hole Interval	30 MESH □0,6										4 mm		4 mm		6 mm		8 mm		10 mm							



Plakada delik konumu

T-1755 Çelik boru / Steel Pipe
T-1765 Çelik boru / Steel Pipe
T-1775 Çelik boru / Steel Pipe

T-1785 Çelik boru / Steel Pipe

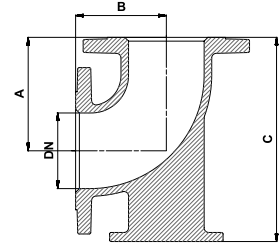
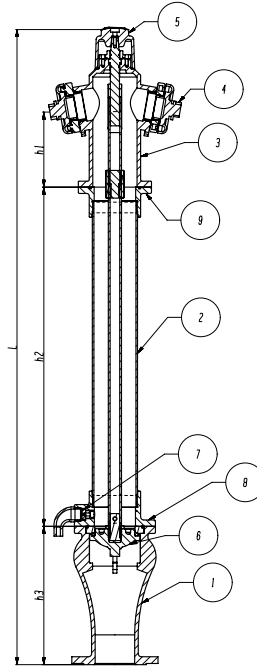

Genel Özellikler / General Specifications

Çalışma Sıcaklık Aralığı / Working Temperature : -10... +120 °C (16 Bar)

Standartlar / Standards

Sertifikalar / Certificates :

Tasarım / Design : TS EN 14384

Bağlantı Boyutları / Connection Dimensions : TS EN 1092-2 (PN 16)

Testler / Tests : TS EN 12266-1

Uygulamalar / Applications

Yangın tesisatları

Fire installations

No	Parça Adı / Part Name	Malzeme / Material
1	Gövde / Body	GG 25 - EN GJL 250 - Pik Döküm / Cast Iron
2	Alt Boru / Lower Pipe	St 37 - Çelik çekme / Steel Extrusion
3	Çatal / Fork	GG 25 - EN GJL 250 - Pik Döküm / Cast Iron
4	Kaplin / Coupling	Alüminyum Alaşım / Aluminum Alloy
5	Volan / Handwheel	GG 25 - EN GJL 250 - Pik Döküm / Cast Iron
6	Klape / Seat Seal	GGG 40 - EN GJS 400-15 - Sfero Döküm + Kauçuk Kaplama / Ductile Iron+rubber plated
7	Çekvalf / Check Valve	CuZn40Pb2- CW617N Pirinç / Brass
8	Alt Flanş / Lower Flange	GG 25 - EN GJL 250 - Pik Döküm / Cast Iron
9	Üst Flanş / Upper Flange	GG 25 - EN GJL 250 - Pik Döküm / Cast Iron

Ürün Kodu / Product code	h1	h2	h3	L
T-1755	190	430	350	1180
T-1765		1000		1750
T-1775		1290		2040
T-1785		1720		2470

Ölçüler / Dimensions	Anma Basıncı / Nominal Pressure	16 Bar
	DN	100
L		T-1755 : 1180
		T-1765 : 1750
		T-1775 : 2040
		T-1785 : 2470
Çıkış Ölçüsü / Outlet Dimension		2x65
Tip / Type		C
Akış Kesme Sistemi / Flow Cut Systems		Kuru Tip / Dry Type
KV Debi Kapasitesi / Flowrate (m ³ / h)		210
Dirsek / Elbow	A	150
	B	120
	C	270

YER ÜSTÜ YANGIN HİDRANTI (PN 16)

- OVERGROUND FIRE HYDRANT (PN 16)



T-1760 Pik Döküm / Cast Iron

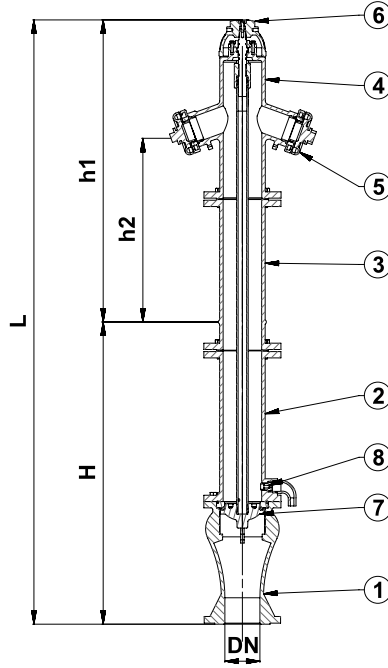

Genel Özellikler / General Specifications

Çalışma Sıcaklık Aralığı / Working Temperature : -10... +120 °C (16 Bar)

Standartlar / Standards

Sertifikalar / Certificates :

Tasarım / Design : TS EN 14384

Bağlantı Boyutları / Connection Dimensions : TS EN 1092-2 (PN 16)

Testler / Tests : TS EN 12266-1

Uygulamalar / Applications

Yangın tesisatları
Fire installations

No	Parça Adı / Part Name	Malzeme / Material
1	Gövde / Body	GG 25 - EN GJL 250 - Pik Döküm / Cast Iron
2	Alt Boru / Lower Pipe	GG 25 - EN GJL 250 - Pik Döküm / Cast Iron
3	Üst Boru / Upper Pipe	GG 25 - EN GJL 250 - Pik Döküm / Cast Iron
4	Çatal / Fork	GG 25 - EN GJL 250 - Pik Döküm / Cast Iron
5	Kaplin / Coupling	Alüminyum Alaşım / Aluminum Alloy
6	Volan / Handwheel	GG 25 - EN GJL 250 - Pik Döküm / Cast Iron
7	Klape / Seat Seal	GGS 40 - EN GJS 400-15 - Sfero Döküm + Kauçuk Kaplama / Ductile Iron + Rubber Coated
8	Çekvalf / Check Valve	CuZn40Pb2 - CW617N - Pirinç / Brass

Ölçüler / Dimensions	Anma Basıncı / Nominal Pressure	16 Bar
	DN	80
	H	560
	L	1750
	Çıkış Ölçüsü / Outlet Dimension	2 x 2"
	Tip / Type	C
	Akış Kesme Sistemi / Flow Cut Systems	Kuru Tip / Dry Type
KV Debi Kapasitesi / Flowrate (m ³ /h)		106

Ölçüler / Dimensions	T-1760	
	Anma Basıncı / Nominal Pressure	16 Bar
	DN	80
	H	290

T-1750 Pik Döküm / Cast Iron
T-1760 Dirsek / Flange Bend
T-1770 Kazan / Surface Box

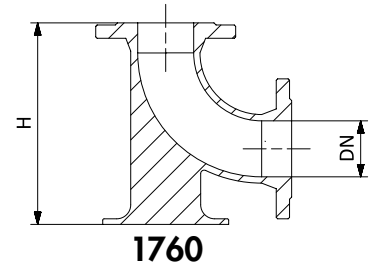
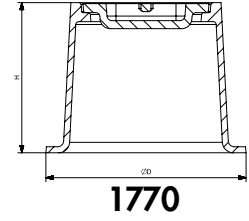
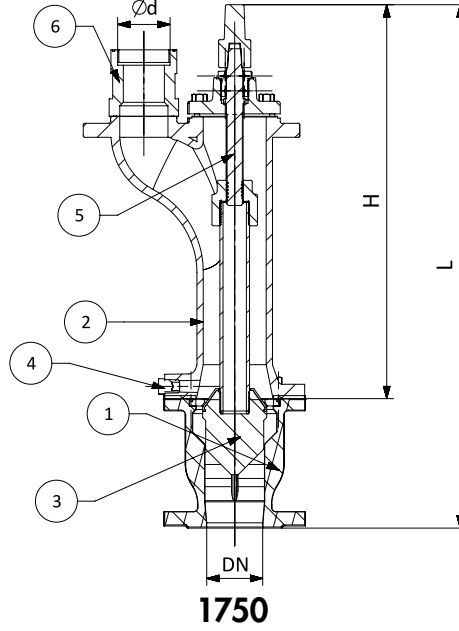

Genel Özellikler / General Specifications

Çalışma Sıcaklık Aralığı / Working Temperature : -10... +120 °C (16 Bar)

Standartlar / Standards

Sertifikalar / Certificates :

Tasarım / Design : TS EN 14339

Bağlantı Boyutları / Connection Dimensions : TS EN 1092-2 (PN 16)

Testler / Tests : TS EN 12266-1

Uygulamalar / Applications

Yangın tesisatları, sulama sistemleri
Fire installations, irrigation systems

No	Parça Adı / Part Name	Malzeme / Material
1	Gövde / Body	GG 25 - EN GJL 250 - Pik Döküm / Cast Iron
2	Üst Gövde / Upper Body	GG 25 - EN GJL 250 - Pik Döküm / Cast Iron
3	Klape / Seat Seal	GGG 40 - EN GJS 400-15 - Sfero Döküm + Kauçuk Kaplama / Ductile Iron + Rubber Coated
4	Çekvalf / Check Valve	CuZn40Pb2 - CW617N - Pirinç / Brass
5	Mil / Stem	X20Cr13 - AISI420 - Paslanmaz Çelik / Stainless Steel
6	Kaplin / Coupling	GG 25 - EN GJL 250 - Pik Döküm / Cast Iron

Ölçüler / Dimensions	T-1750	
	Anma Basıncı / Nominal Pressure	16 Bar
	DN	80
	H	560
	L	750
	Çıkış Ölçüsü / Outlet Dimension	1 x 2 1/2"
	Tip / Type	C
	Akış Kesme Sistemi / Flow Cut Systems	Kuru Tip / Dry Type
	KV Debi Kapasitesi / Flowrate (m ³ / h)	106

Ölçüler / Dimensions	T-1760		Ölçüler / Dimensions	T-1770	
	Anma Basıncı / Nominal Pressure	16 Bar		Anma Basıncı / Nominal Pressure	16 Bar
	DN	80		Ø D	360
	H	290	H	270	

Y Tipi Pislik Tutucu

Y Type Strainer

Lug Küresel Vana

Lug Ball Valve

Statik Balans Vanası

Static Balancing Valve

Vulkanize Kaplı Kelebek Vana

Vulcanized Butterfly Valve

HVAC Grubu

HVAC Group

Yangın Grubu

Fire Group

Akış Anahtarı

Flow Switch

Sprinkler Başlıkları

Sprinkler Heads

Test & Drenaj Vanası

Test & Drain Valve

İzlenebilir Kelebek Vana

Indicating Butterfly Valve

+90
444 VANA
8262

www.duyarvana.com.tr | www.duyarvalve.com

T-1810 Sfero Döküm Flaşlı DN 25-300 / Ductile Iron Flange
T-1810 Çelik Flaşlı DN 350-600 / Steel Flange

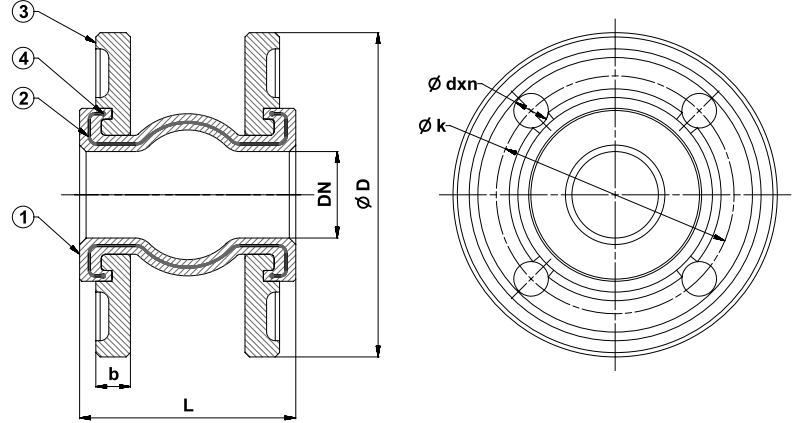

Genel Özellikler / General Specifications

Çalışma Sıcaklık Aralığı / Working Temperature : -20... +90 °C
40 °C (16 Bar), 60 °C (10 Bar), 90 °C (6 Bar)

Standartlar / Standards

Sertifikalar / Certificates :

Tasarım / Design : TS 10879

Bağlantı Boyutları / Connection Dimensions : TS EN 1092-2 (PN 16)

Testler / Tests : TS EN 12266-1

Uygulamalar / Applications

Sıcak ve soğuk su sistemleri, asit ve alkali özelliği bulunmayan sıvı akışkanlar, sıvı yakıt tesisatları

Hot and cold water systems, non-acidic and non-flammable liquid fluids, liquid fuel systems

No	Parça Adı / Part Name	Malzeme / Material
1	Gövde / Body	Kauçuk / Rubber
2	Kort Bezi / Cord Fabric	Sentetik Fiber / Nylon 6.6
3	Flaş / Flange	DN 25-300, GGG 40 - EN GJS 400-15 - Sfero Döküm + Galvaniz Kaplama / Ductile Iron + Galvanize Plated DN 350-600, St 37 - Çelik + Galvaniz Kaplama / Steel + Galvanize Plated
4	Segman / Piston Ring	Karbon Çelik / Carbon Steel

Anma Basıncı / Nominal Pressure	16 Bar																				
	Anma Çapı / Nominal Diameter	DN	25	32	40	50	65	80	100	125	150	200	250	300	350	400	450	500	600		
Ölçüler / Dimensions	Vana Boyutları / Valve Dimensions	L	100						120			115	130	160	240	250	270	260			
		ØD	115	150	165	185	200	220	250	285	340	405	460	520	565	615	670	780			
		Eksenel Genleşme / Axial Expansion	+ 10mm																		
		Eksenel Kapanma / Axial Compression	-20mm																		
		Yanal Hareket / Lateral Movement	15mm																		
		Açısal Hareket / Angular Movement	10°																		
		k	85	100	110	125	145	160	180	210	240	295	355	410	470	515	565	620	725		
		b	16		18			20		22		24		26		28		28			
		dxn	14x4	19x4			19x8			23x8		23x12		26x12		26x16		26x20		30x20	
		Ağırlık / Weight	Kg	1,8	3,3	3,8	4,5	5,2	6,7	7,8	9,6	11,8	16,8	20	28	42,4	46	51	57	70	

T-1815 Pik Döküm / Cast Iron

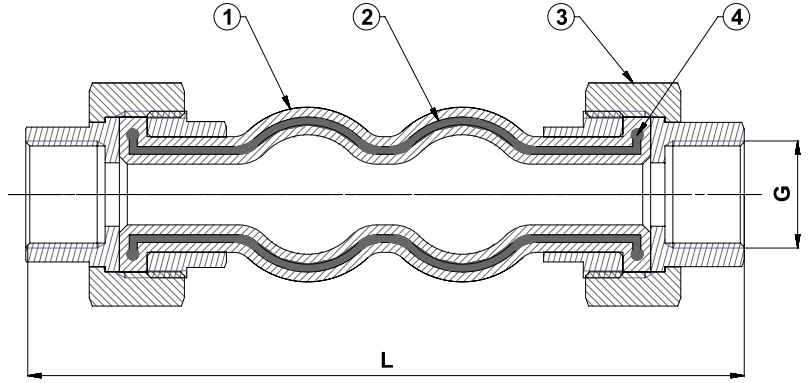

Genel Özellikler / General Specifications

Çalışma Sıcaklık Aralığı / Working Temperature : -20... +115 °C
40 °C (16 Bar), 60 °C (10 Bar), 90 °C (6 Bar)

Standartlar / Standards

Sertifikalar / Certificates : CE, PED

Tasarım / Design : TS 10879

Diş Standardı / Thread Standard : ISO 7 - 1 DIN 2999, BSPT

Testler / Tests : TS EN 12266-1

Uygulamalar / Applications

Sıcak ve soğuk su sistemleri, asit ve alkali özelliği bulunmayan sıvı akışkanlar, sıvı yakıt tesisatları
Hot and cold water systems, non-acidic and non-flammable liquid fluids, liquid fuel systems

Malzeme Özellikleri / Material Specifications	No	Parça Adı / Part Name	Malzeme / Material
	1	Gövde / Body	Kauçuk / Rubber
	2	Kort Bezi / Kord Fabric	Sentetik Fiber / Nylon 6.6
	3	Rakor / Rotary Joint	Dövülebilir Dökme Demir / Forgeable Cast Iron
	4	Segman / Piston Ring	Karbon Çelik / Carbon Steel

Ölçüler / Dimensions	Anma Basıncı / Nominal Pressure	16 Bar								
	Anma Çapı / Nominal Diameter	DN	15	20	25	32	40	50	65	80
Vana Boyutları / Valve Dimensions	G	1 / 2"	3 / 4"	1"	1 1 / 4"	1 1 / 2"	2"	2 1 / 2"	3"	
	L	180			200	210	220	245	285	
	Eksenel Genleşme / Axial Expansion	+ 6mm								
	Eksenel Kapanma / Axial Compression	-16mm								
	Yanal Hareket / Lateral Movement	15mm								
Açısal Hareket / Angular Movement	10°									
Ağırlık / Weight	Kg	0,5	0,75	1	1,4	2	2,6	4	5,6	

T-1820 Movement 30mm (-20 ... +10 mm) DN 25-250
T-1840 Movement 60mm (-40 ... +20 mm) DN 50-250

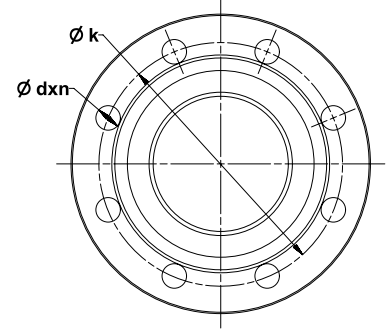
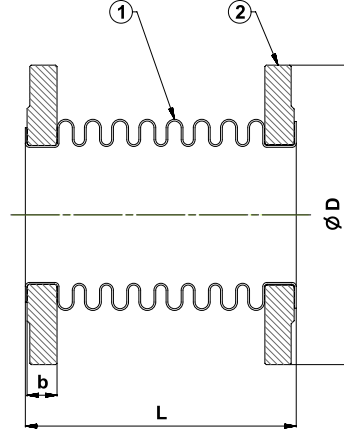

Genel Özellikler / General Specifications

Çalışma Sıcaklık Aralığı / Working Temperature : -80 ... +420°C (16 Bar)

Standartlar / Standards

Sertifikalar / Certificates :

Tasarım / Design : TS 10880

Bağlantı Boyutları / Connection Dimensions : TS EN 1092-1 (PN 16)

Testler / Tests : TS EN 12266-1

Malzeme Özellikleri / Material Specifications	No	Parça Adı / Part Name	Malzeme / Material
	1	Körük / Bellow	X5CrNi18 10 - AISI304 - Paslanmaz Çelik / Stainless Steel
2	Flanş / Flange	St37 - Çelik / Steel	

Uygulamalar / Applications

Sıcak ve soğuk su sistemleri, basınçlı hava, kızgın su, buhar, kızgın buhar, kızgın yağ sistemleri
Hot and cold water systems, compressed air, superheated water, steam, superheated steam systems, superheated oil systems

Ölçüler / Dimensions	Anma Basıncı / Nominal Pressure	16 Bar												
	Anma Çapı / Nominal Diameter	DN	25	32	40	50	65	80	100	125	150	200	250	300
T-1820	L 30mm (-20 ... +10mm)		120			125		115	120		130	150		160
	T-1840	L 60mm (-40 ... +20mm)				180	175	180	190	185	200	220		230
T-1820	Eksenel Hareket / Axial Movement	30mm (-20 ... +10mm)												
		60mm (-40 ... +20mm)												
Vana Boyutları / Valve Dimensions (mm)	ØD	115	140	150	165	185	200	220	250	285	340	405	460	
	k	85	100	110	125	145	160	180	210	240	295	355	410	
	b	16	18		20		22			24	26	28	28	
	dxn	14x4	18x4			18x8			22x8		22x12	27x12		

METAL KÖRÜKLÜ KOMPANSATÖR (DÖNER FLANŞLI, LAYNERLİ, PN 16)

-METAL BELLOWS EXPANSION JOINTS (ROTARY FLANGED, WITH LINER, PN 16)



T-1830 Movement 30mm (-20 ... +10 mm) DN 25 - 250
T-1850 Movement 60mm (-40 ... +20 mm) DN 50 - 250

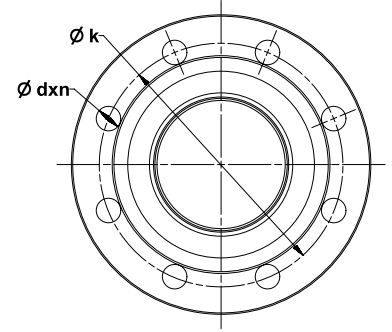
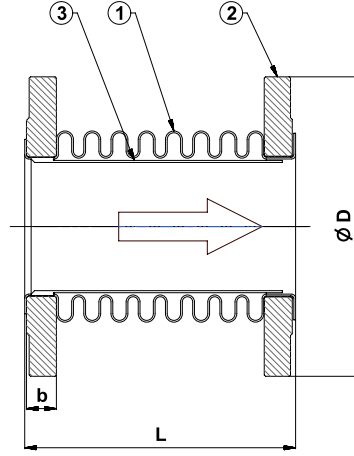

Genel Özellikler / General Specifications

Çalışma Sıcaklık Aralığı / Working Temperature : -80 ... +420°C (16 Bar)

Standartlar / Standards

Sertifikalar / Certificates :

Tasarım / Design : TS 10880

Bağlantı Boyutları / Connection Dimensions : TS EN 1092-1 (PN 16)

Testler / Tests : TS EN 12266-1

Malzeme Özellikleri / Material Specifications	No	Parça Adı / Part Name	Malzeme / Material
	1	Körük / Bellow	X5CrNi18 10 - AISI304 - Paslanmaz Çelik / Stainless Steel
	2	Flanş / Flange	St37 - Çelik / Steel
	3	Layner / Liner	X5CrNi18 10 - AISI304 - Paslanmaz Çelik / Stainless Steel

Uygulamalar / Applications

Sıcak ve soğuk su sistemleri, basınçlı hava, kızgın su, buhar, kızgın buhar, kızgın yağ sistemleri
Hot and cold water systems, compressed air, superheated water, steam, superheated steam systems, superheated oil systems

Ölçüler / Dimensions	Anma Basıncı / Nominal Pressure	16 Bar													
	Anma Çapı / Nominal Diameter	DN	25	32	40	50	65	80	100	125	150	200	250	300	
T-1830	L 30mm (-20 ... +10mm)	120			125		115		120		130		150		160
		120			125		115		120		130		150		160
T-1850	L 60mm (-40 ... +20mm)	120			125		115		120		130		150		160
T-1830	Eksenel Hareket / Axial Movement	30mm (-20 / +10mm)													
		60mm (-40 / +20mm)													
Vana Boyutları / Valve Dimensions (mm)	ØD	115	140	150	165	185	200	220	250	285	340	405	460		
	k	85	100	110	125	145	160	180	210	240	295	355	410		
	b	16	18		20		22		24		26	28	28		
	dxn	14x4	18x4			18x8			22x8		22x12		27x12		

T-1950 Movement 30mm (- 20 ... +10 mm) DN 25 - 250
T-1960 Movement 60mm (- 40 ... +20 mm) DN 50 - 250

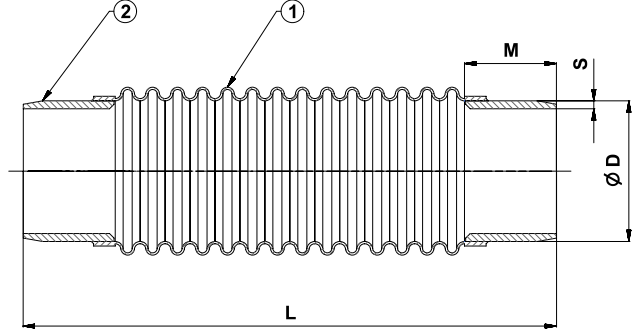

Genel Özellikler / General Specifications

Çalışma Sıcaklık Aralığı / Working Temperature : -80 ... +420°C (16 Bar)

Standartlar / Standards

Sertifikalar / Certificates : CE P3

Tasarım / Design : TS 10880

Bağlantı Boyutları / Connection Dimensions : TS EN 1092-1 (PN 16)

Testler / Tests : TS EN 12266-1

Uygulamalar / Applications

Sıcak ve soğuk su sistemleri, basınçlı hava, kızgın su, buhar, kızgın buhar, kızgın yağ sistemleri
Hot and cold water systems, compressed air, superheated water, steam, superheated steam systems, superheated oil systems

Malzeme Özellikleri / Material Specifications

No	Parça Adı / Part Name	Malzeme / Material
1	Körük / Bellow	X5CrNi18 10 - AISI304 - Paslanmaz Çelik / Stainless Steel
2	Kaynak Boynu / Welded Neck	St37 - Çelik / Steel

Ölçüler / Dimensions	Anma Basıncı / Nominal Pressure	16 Bar												
	Anma Çapı / Nominal Diameter	DN	25	32	40	50	65	80	100	125	150	200	250	300
T-1950	L 30mm (-20 ... +10mm)		195			190	190	190	200	200	250	270	300	
T-1960	L 60mm (- 40 ... +20mm)					240			270	320	340	370	380	
T-1950	Eksenel Hareket / Axial Movement	30mm (- 20 / +10mm)												
T-1960		60mm (- 40 / +20mm)												
Vana Boyutları / Valve Dimensions (mm)	ØD	38	42,4	48,3	60,3	76,1	88,9	114,3	139,7	165,1	219,1	273,1	323,9	
	S	2,6	2,6	3			3,2	3,6	4	4,5	5,9	6,3	7,1	
	M				50			60		80		100		

Kaynak Ağızı TS 5437'ye Uygundur / Welding Neck TS 5437 Standard

T-1970 / T-1980 / T-1985

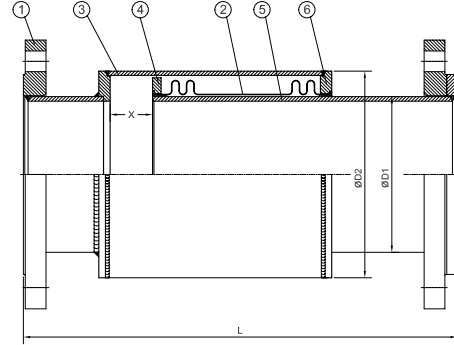

Genel Özellikler / General Specifications

Çalışma Sıcaklık Aralığı / Working Temperature : -80 ... +420°C (16 Bar)

Genleşme Miktarı

DN 25 - 250	T-1970 Movement 30mm (-20 ... +10 mm)
	T-1980 Movement 60mm (-40 ... +20 mm)
	T-1985 Movement 90mm (-60 ... +30 mm)

Standartlar / Standards

Sertifikalar / Certificates :

Tasarım / Design : TS 10880

Bağlantı Boyutları / Connection Dimensions : TS EN 1092-1 (PN 16)

Testler / Tests : TS EN 12266-1

Uygulamalar / Applications

Sıcak ve soğuk su sistemleri, basınçlı hava, kızgın su, buhar, kızgın buhar, kızgın yağ sistemleri
 Hot and cold water systems, compressed air, superheated water, steam, superheated steam systems, superheated oil systems

Malzeme Özellikleri / Material Specifications	No	Parça Adı / Part Name	Malzeme / Material
	1	Flanş / Flange	St37 - Çelik / Steel
	2	Körük / Bellow	X5CrNi18 10 - AISI304 - Paslanmaz Çelik / Stainless Steel
	3	Dış Boru / Outer Pipe	St33 - Çelik / Steel (DIN 2440B, TS 301/3)
	4	İç Flanş / Inner Flange	St37 - Çelik / Steel
	5	Kayar Boru / Sliding Pipe	St33 - Çelik / Steel (DIN 2440B, TS 301/3)
6	Dış Flanş / Outer Flange	St37 - Çelik / Steel	

Ölçüler / Dimensions	Anma Basıncı / Nominal Pressure	16 Bar												
	Anma Çapı / Nominal Diameter	DN	25	32	40	50	65	80	100	125	150	200	250	300
	T-1970	L 30mm (-20 / +10mm)	285			290			300		350	360	390	410
	T-1980	L 60mm (-40 / +20mm)	440			370		385	400	460	480	490	510	
	T-1985	L 90mm (-70 / +20mm)	600			530			540	550	620	650	660	690
	T-1970	"EKSENEL HAREKET Axial Movement"	30mm (-20 / +10mm)											
	T-1980		60mm (-40 / +20mm)											
	T-1985		90mm (-60 / +30mm)											
	T-1970	X	25											
	T-1980		45											
T-1985	65													
Vana Boyutları / Valve Dimensions (mm)	ØD1		42,4	48,3	60,3	76,1	88,9	114,3	139,7	165,1	219,1	273,1		
	ØD2		76,1	88,9	114,3	139,7	165,1	219,1	219,1	323,9	355,6	406,4		

T-1990 / T-1995 / T-1996

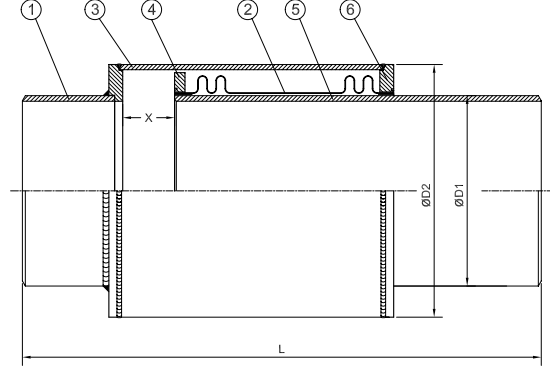

Genel Özellikler / General Specifications

Çalışma Sıcaklık Aralığı / Working Temperature : -80 ... +420°C (16 Bar)

Genleşme Miktarı / Expansion - Compression

DN 25 - 250	T-1990 Movement 30mm (-20 ... +10 mm)
	T-1995 Movement 60mm (-40 ... +20 mm)
	T-1996 Movement 90mm (-60 ... +30 mm)

Standartlar / Standards

Sertifikalar / Certificates :

Tasarım / Design : TS 10880

Bağlantı Boyutları / Connection Dimensions : TS EN 1092-1 (PN 16)

Testler / Tests : TS EN 12266-1

Uygulamalar / Applications

Sıcak ve soğuk su sistemleri, basınçlı hava, kızgın su, buhar, kızgın buhar, kızgın yağ sistemleri
 Hot and cold water systems, compressed air, superheated water, steam, superheated steam systems, superheated oil systems

Malzeme Özellikleri / Material Specifications	No	Parça Adı / Part Name	Malzeme / Material
	1	Kaynak Boynu / Welded Neck	St37 - Çelik / Steel
	2	Körük / Bellow	X5CrNi18 10 - AISI304 - Paslanmaz Çelik / Stainless Steel
	3	Dış Boru / Outer Pipe	St33 - Çelik / Steel (DIN 2440B, TS 301/3)
	4	İç Flanş / Inner Flange	St37 - Çelik / Steel
	5	Kayar Boru / Sliding Pipe	St33 - Çelik / Steel (DIN 2440B, TS 301/3)
	6	Dış Flanş / Outer Flange	St37 - Çelik / Steel

Ölçüler / Dimensions	Anma Basıncı / Nominal Pressure	16 Bar												
	Anma Çapı / Nominal Diameter	DN	25	32	40	50	65	80	100	125	150	200	250	300
	T-1990	L 30mm (-20 / +10mm)	250			255			260		310	320	345	350
	T-1995	L 60mm (-40 / +20mm)	410			335		350	360	420	440		450	
	T-1996	L 90mm (-60 / +30mm)	570			500			510	580	610	615	630	
	T-1990	Eksenel Hareket / Axial Movement	30mm (-20 / +10mm)											
	T-1995		60mm (-40 / +20mm)											
	T-1996		90mm (-60 / +30mm)											
	T-1990		25											
	T-1995		45											
T-1996	65													
Vana Boyutları / Valve Dimensions (mm)	ØD1	38	42,4	48,3	60,3	76,1	88,9	114,3	139,7	165,1	219,1	273,1	323,9	
	ØD2	76,1	76,1	88,9	114,3	139,7	165,1	219,1	323,9	355,6	406,4			

LİMİT ROTLU METAL KOMPANSATÖR PN16 (FLANGED)

-METAL BELLOWS EXPANSION JOINTS, WITH LIMITING ROD PN16 (FLANGED)



T-1825 / T-1845

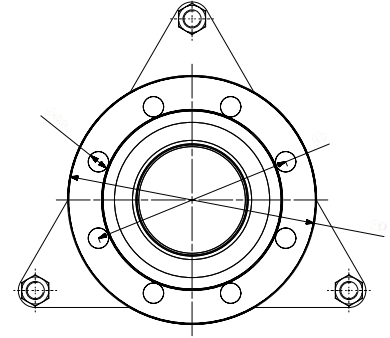
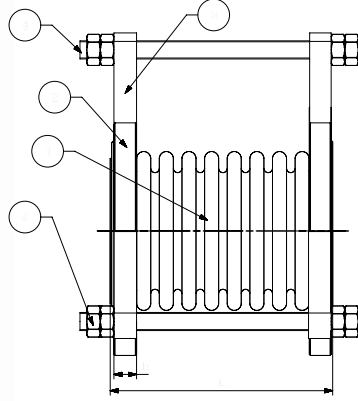

Genel Özellikler / General Specifications

Çalışma Sıcaklık Aralığı / Working Temperature : -80 ... +420 °C (16 Bar)

Standartlar / Standards

Sertifikalar / Certificates :

Tasarım / Design : TS 10880

Bağlantı Boyutları / Connection Dimensions : TS EN 1092-1 (PN 16)

Testler / Tests : TS EN 12266-1

Uygulamalar / Applications

Sıcak ve soğuk su sistemleri, basınçlı hava, kızgın su, buhar, kızgın buhar, kızgın yağ sistemleri

Hot and cold water systems, compressed air, superheated water, steam, superheated steam systems, superheated oil systems

Malzeme Özellikleri / Material Specifications	No	Parça Adı / Part Name	Malzeme / Material
	1	Körük / Bellow	X5CrNi18 10 Paslanmaz Çelik / Stainless Steel 1.4301
	2	Flanş / Flange	X5CrNi18 10 Paslanmaz Çelik / Stainless Steel 1.4301
	3	Kulak / Additional Part	X5CrNi18 10 Paslanmaz Çelik / Stainless Steel 1.4301
	4	Somun / Intermediate pipe	Sı37-2 - Çelik / Steel
	5	Limit Rot / Limit rod	Sı37-2 - Çelik / Steel

Ölçüler / Dimensions	Anma Basıncı / Nominal Pressure	16 Bar												
	Anma Çapı / Nominal Diameter	DN	25	32	40	50	65	80	100	125	150	200	250	300
	Vana Boyutları / Valve Dimensions	ØD	115	140	150	165	185	200	220	250	285	340	405	460
		k	85	100	110	125	145	160	180	210	240	295	355	410
		b	16	18		20			22		24	26	28	
		dxn	14x4	18x4				18x8			23x8	23x12	27x12	
		L	120			125		115	120		130	150		160

T-2610 / T-2620 / T-2650

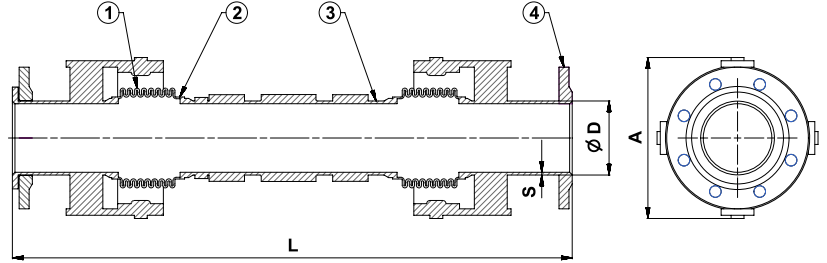

Genel Özellikler / General Specifications

Çalışma Sıcaklık Aralığı / Working Temperature : -80 ... +420°C (16 Bar)

Genleşme Miktarı / Expansion - Compression

DN 25 - 250	(T-2610) Movement Eksenel (Axial) X=100mm, Yanal (Lateral) Y=±50mm (100) Açısal (Angular) Z=±50mm(100)
	(T-2620) Movement Eksenel (Axial) X=100mm, Yanal (Lateral) Y=±100mm (200) Açısal (Angular) Z=±100mm(200)
	(T-2650) Movement Eksenel (Axial) X=100mm, Yanal (Lateral) Y=±200mm (400) Açısal (Angular) Z=±200mm(400)

Standartlar / Standards

Sertifikalar / Certificates :

Tasarım / Design : TS 10880

Bağlantı Boyutları / Connection Dimensions : TS EN 1092-1 (PN 16)

Testler / Tests : TS EN 12266-1

Uygulamalar / Applications

Sıcak ve soğuk su sistemleri, basınçlı hava, kızgın su, buhar, kızgın buhar, kızgın yağ sistemleri, bütün boru hatlarında
Hot and cold water systems, compressed air, superheated water, steam, superheated steam systems, superheated oil systems, all pipe lines

Malzeme Özellikleri / Material Specifications	No	Parça Adı / Part Name	Malzeme / Material
	1	Körük / Bellow	X5CrNi18 10 - AISI304 - Paslanmaz Çelik / Stainless Steel
	2	Bant / Band	X5CrNi18 10 - AISI304 - Paslanmaz Çelik / Stainless Steel
	3	Ara Boru / Intermediate Pipe	St37 - Çelik / Steel
4	Flanş / Flange	St37 - Çelik / Steel	

Ölçüler / Dimensions	Anma Basıncı / Nominal Pressure		16 Bar														
	Anma Çapı / Nominal Diameter	X = Eksenel Hareket / Axial Movement	Y = Yanal Hareket / Lateral Movement	Z = Açısal Hareket / Angular Movement	DN	25	32	40	50	65	80	100	125	150	200	250	300
	T-2610	100	±50mm (100)	±50mm (100)	L	720		785		840		970		1160		1210	
	T-2620		±100mm (200)	±100mm (200)		920		985		1040		1170		1360		1410	
T-2650	±200mm (400)		±200mm (400)	1320		1385 1485		1540		1770		2060		2160			
					ØD	33,2	42,4	48,3	60,3	76,1	88,9	114,3	139,7	165,1	219,1	273,1	323,9
					A	114		133	148	167	202	255	280	328	380	442	507
					S	2,3	2,6	3,0		3,2	3,6	4	4,5	6,3	7,1	7,1	
					Vana Boyutları / Valve Dimensions (mm)												

T-2710 / T-2720 / T-2750

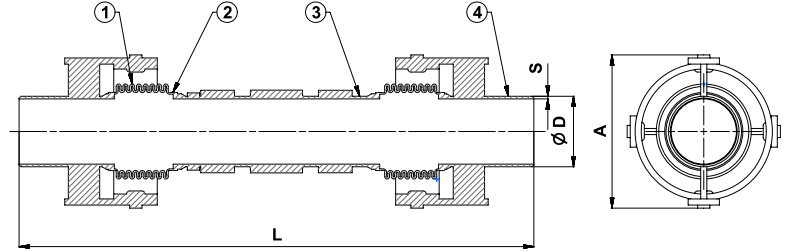
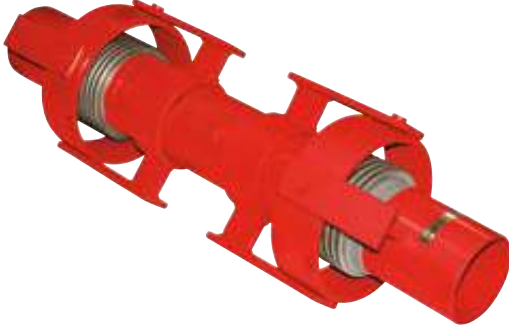

Genel Özellikler / General Specifications

Çalışma Sıcaklık Aralığı / Working Temperature : -80 ... +420°C (16 Bar)

Genleşme Miktarı / Expansion - Compression

DN 25 - 250	(T-2710) Movement Eksenel (Axial) X=100mm, Yanal (Lateral) Y= ±50mm (100) Açısal (Angular) Z=±50mm (100)
	(T-2720) Movement Eksenel (Axial) X=100mm, Yanal (Lateral) Y= ±100mm (200) Açısal (Angular) Z=±100mm(200)
	(T-2750) Movement Eksenel (Axial) X=100mm, Yanal (Lateral) Y= ±200mm (400) Açısal (Angular) Z=±200mm(400)

Standartlar / Standards

Sertifikalar / Certificates : CE PED

Tasarım / Design : TS 10880

Bağlantı Boyutları / Connection Dimensions : TS EN 1092-1 (PN 16)

Testler / Tests : TS EN 12266-1

Uygulamalar / Applications

Sıcak ve soğuk su sistemleri, basınçlı hava, kızgın su, buhar, kızgın buhar, kızgın yağ sistemleri, bütün boru hatlarında
 Hot and cold water systems, compressed air, superheated water, steam, superheated steam systems, superheated oil systems, all pipe lines

Malzeme Özellikleri / Material Specifications	No	Parça Adı / Part Name	Malzeme / Material
	1	Körük / Bellow	X5CrNi18 10 - AISI304 - Paslanmaz Çelik / Stainless Steel
	2	Bant / Band	X5CrNi18 10 - AISI304 - Paslanmaz Çelik / Stainless Steel
	3	Ara Boru / Intermediate Pipe	St37 - Çelik / Steel
4	Kaynak Boynu / Welded Neck	St37 - Çelik / Steel	

Ölçüler / Dimensions	Anma Basıncı / Nominal Pressure	16 Bar																		
	Anma Çapı / Nominal Diameter	X = Eksenel Hareket / Axial Movement	Y = Yanal Hareket / Lateral Movement	Z = Açısal Hareket / Angular Movement	DN	25	32	40	50	65	80	100	125	150	200	250	300			
	T-2710	100	±50mm (100)	±50mm (100)	L	715		780		830		960		1150		1200				
	T-2720		±100mm (200)	±100mm (200)		915		980		1030		1160		1350		1400				
T-2750	±200mm (400)		±200mm (400)	1315		1380 1480		1530		1760		2050		2150						
					ØD	33,2	42,4	48,3	60,3	76,1	88,9	114,3	139,7	165,1	219,1	273,1	323,9			
					A	142		162	168	186	232	282	308	355	435	515	507			
					S	2,3	2,6	3		3,2		3,6	4	4,5	6,3	7,1	7,1			
					Vana Boyutları / Valve Dimensions (mm)															

T-2420 / T-2440 / T-2460 / T-2480

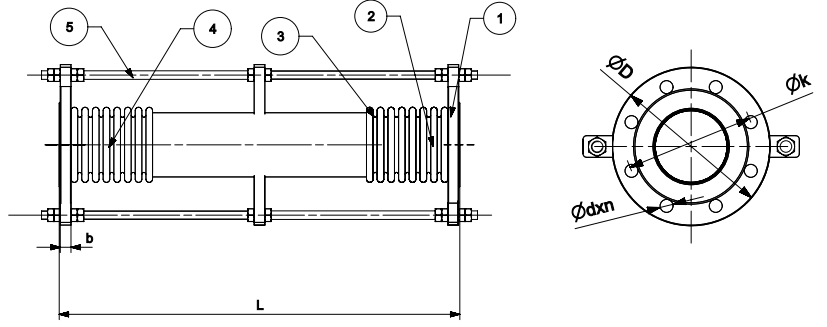

Genel Özellikler / General Specifications

Çalışma Sıcaklık Aralığı / Working Temperature : -80 ... +420°C (16 Bar)

Genleşme Miktarı / Expansion - Compression

DN 25 - 50
T-2420 Movement Eksenel (Axial) X=30mm, Yanal(Lateral) Y= ±50mm (100)
T-2440 Movement Eksenel (Axial) X=30mm, Yanal(Lateral) Y= ±100mm (200)

DN 65 - 300
T-2460 Movement Eksenel(Axial) X=60mm, Yanal (Lateral) Y= ±50mm (100)
T-2480 Movement Eksenel(Axial) X=60mm, Yanal (Lateral) Y= ±100mm (200)

Standartlar / Standards

Sertifikalar / Certificates :

Tasarım / Design : TS 10880

Bağlantı Boyutları / Connection Dimensions : TS EN 1092-1 (PN 16)

Testler / Tests : TS EN 12266-1

Uygulamalar / Applications

Sıcak ve soğuk su sistemleri, basınçlı hava, kızgın su, buhar, kızgın buhar, kızgın yağ sistemleri
Hot and cold water systems, compressed air, superheated water, steam, superheated steam systems, superheated oil systems

Malzeme Özellikleri / Material Specifications	No	Parça Adı / Part Name	Malzeme / Material
	1	Flanş / Flange	St37-2 - Çelik / Steel
	2	Körük / Bellow	X5CrNi18 10 Paslanmaz Çelik / Stainless Steel 1.4301
	3	Bant / Band	X5CrNi18 10 Paslanmaz Çelik / Stainless Steel 1.4301
	4	Ara Boru / Intermediate Pipe	St37-2 - Çelik / Steel
	5	Limit Rot / Limit Rod	St37-2 - Çelik / Steel

Ölçüler / Dimensions	Anma Basıncı / Nominal Pressure	16 Bar																	
		Anma Çapı / Nominal Diameter	X = Eksenel Hareket / Axial Movement	Y = Yanal Hareket / Lateral Movement	Z = Açısal Hareket / Angular Movement	DN	25	32	40	50	65	80	100	125	150	200	250	300	
	T-2420						30	±50mm (100)			L	350			360	420			
	T-2440	550			560	620													
	T-2460	60	±50mm (100)			L				430	470	600	670	750	750				
	T-2480									630	670	800	870	950	950				
Boyutlar / Dimensions [mm]			ØD			115	140	150	165	185	200	220	250	285	340	405			
			k			85	100	110	125	145	160	180	210	240	295	355			
			b			16	18	20		22		24	26	28					
			dxn			14x4		18x4			18x8			22x8		22x12			

T-2520 / T-2540 / T-2560 / T-2580

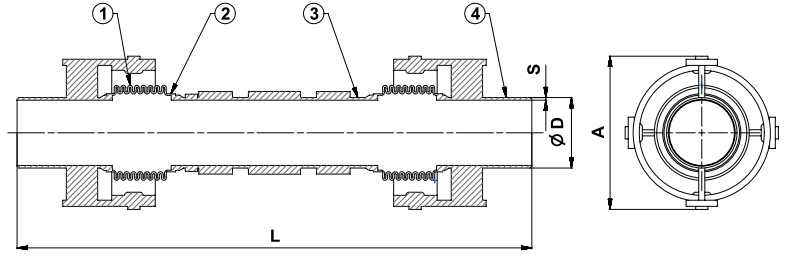

Genel Özellikler / General Specifications

Çalışma Sıcaklık Aralığı / Working Temperature : -80 ... +420°C (16 Bar)

Genleşme Miktarı / Expansion - Compression

DN 25 - 50 T-2520 Movement Eksenal (Axial) X=30mm, Yanal(Lateral) Y= ±50mm (100)
 T-2540 Movement Eksenal (Axial) X=30mm, Yanal(Lateral) Y= ±100mm (200)

DN 65 - 300 T-2560 Movement Eksenal(Axial) X=60mm, Yanal (Lateral) Y= ±50mm (100)
 T-2580 Movement Eksenal(Axial) X=60mm, Yanal (Lateral) Y= ±100mm (200)

Standartlar / Standards

Sertifikalar / Certificates : CE PED

Tasarım / Design : TS 10880

Bağlantı Boyutları / Connection Dimensions : TS EN 1092-1 (PN 16)

Testler / Tests : TS EN 12266-1

Uygulamalar / Applications

Sıcak ve soğuk su sistemleri, basınçlı hava, kızgın su, buhar, kızgın buhar, kızgın yağ sistemleri
 Hot and cold water systems, compressed air, superheated water, steam, superheated steam systems, superheated oil systems

Malzeme Özellikleri / Material Specifications	No	Parça Adı / Part Name	Malzeme / Material
	1	Kaynak Boynu / Welded Neck	St37 - Çelik / Steel
	2	Körük / Bellow	X5CrNi18 10 - AISI304 - Paslanmaz Çelik / Stainless Steel
	3	Bant / Band	X5CrNi18 10 - AISI304 - Paslanmaz Çelik / Stainless Steel
	4	Ara Boru / Intermediate Pipe	St37 - Çelik / Steel
5	Limit Rot / Limit Rod	St37 - Çelik / Steel	

Ölçüler / Dimensions	Anma Basıncı / Nominal Pressure	16 Bar															
	Anma Çapı / Nominal Diameter	X = Eksenal Hareket / Axial Movement	Y = Yanal Hareket / Lateral Movement	Z = Açısal Hareket / Angular Movement	DN	25	32	40	50	65	80	100	125	150	200	250	300
	T-2520	30	±50mm (100)	±100mm (200)	L	620	630	680									
T-2540	820					830	880										
T-2560	60	±50mm (100)	±100mm (200)	L					690	730	850	920	1000	1000			
T-2580								890	930	1050	1120	1200	1200				
Boyutlar / Dimensions [mm]			ØD		33,2	42,4	48,3	60,3	76,1	88,9	114,3	139,7	165,1	219,1	273,1		
			S		2,3	2,6		3,0		3,2	3,6	4	4,5	6,3	7,1		

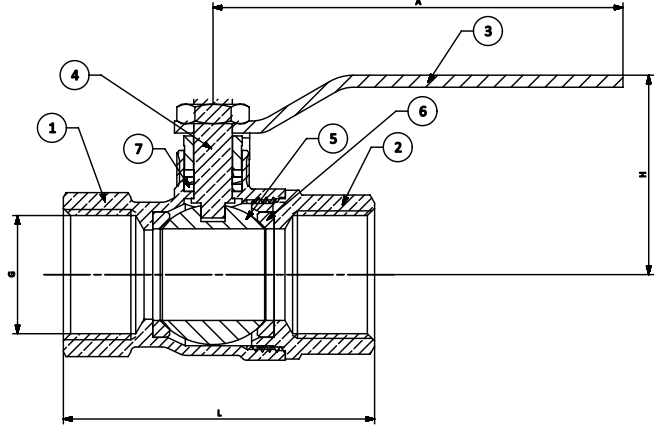

Genel Özellikler / General Specifications

Çalışma Sıcaklık Aralığı / Working Temperature : -10 ... +120 °C (25 Bar)

Standartlar / Standards

Sertifikalar / Certificates :

Tasarım / Design : TS EN 13547

Diş Standardı / Thread Standard : EN ISO 228-1

Testler / Tests : TS EN 12266-1

Uygulamalar / Applications

Sıcak ve soğuk su sistemleri, basınçlı hava, asit ve alkali özelliği bulunmayan sıvı akışkanlar
Hot and cold water systems, compressed air, non-acidic and non-flammable liquid fluids

Malzeme Özellikleri / Material Specifications	No	Parça Adı / Part Name	Malzeme / Material
	1	Gövde / Body	CuZn40Pb2 - CW617N - Pirinç Dövme / Forced Brass
	2	Kapak / Bonnet	CuZn40Pb2 - CW617N - Pirinç Dövme / Forced Brass
	3	Kol / Lever	St37 - Çelik + Galvaniz + Vinil Kaplama / Steel + Galvanize Plated + Vinyl Coated
	4	Mil / Stem	CuZn40Pb2 - CW617N - Pirinç / Brass
	5	Küre / Ball	CuZn40Pb2 - CW617N - Pirinç + Krom Kaplama / Brass + Chrome Plated
	6	Ringler / Seals	PTFE - Teflon
	7	Salmastra	PTFE - Teflon

Ölçüler / Dimensions	Anma Basıncı / Nominal Pressure	25 Bar						16 Bar			
	Anma Çapı / Nominal Diameter	DN	15	20	25	32	40	50	65	80	100
	Vana Boyutları / Valve Dimensions	G	1 / 2"	3 / 4"	1"	1 1 / 4"	1 1 / 2"	2"	2 1 / 2"	3"	4"
		L	46	55	65	80	90	104	150	180	
		H	40	45	60	65	80	85	110	122	132
		A	83		117		163		220		
Ağırlık / Weight	Kg	0,15	0,23	0,45	0,65	0,96	1,43	3,63	5,6	9,1	

PİRİNÇ KÜRESEL VANA, KELEBEK KOLLU (DİŞLİ, PN 25)

-BRASS BALL VALVE, WITH BUTTERFLY LEVER (THREADED, PN 25)



T-2120 Pirinç Dövme / Forced Brass

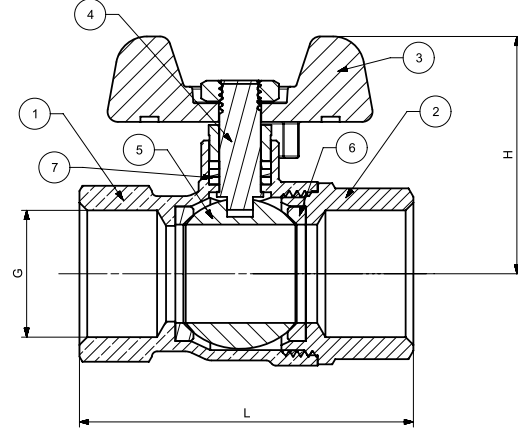

Genel Özellikler / General Specifications

Çalışma Sıcaklık Aralığı / Working Temperature : -10 ... +120°C (25 Bar)

Standartlar / Standards

Sertifikalar / Certificates :  

Tasarım / Design : TS EN 13547

Diş Standardı / Thread Standard : EN ISO 228-1

Testler / Tests : TS EN 12266-1

Uygulamalar / Applications

Sıcak ve soğuk su sistemleri, basınçlı hava, asit ve alkali özelliği bulunmayan sıvı akışkanlar

Hot and cold water systems, compressed air, non-acidic and non-flammable liquid fluids

No	Parça Adı / Part Name	Malzeme / Material
1	Gövde / Body	CuZn40Pb2 - CW617N - Pirinç Dövme / Forced Brass
2	Kapak / Bonnet	CuZn40Pb2 - CW617N - Pirinç Dövme / Forced Brass
3	Kol / Lever	Alüminyum Enjeksiyon + Elektrostatik Boya / Aluminum Injection + Electrostatic Painting
5	Mil / Stem	CuZn40Pb2 - CW617N - Pirinç / Brass
6	Küre / Ball	CuZn40Pb2 - CW617N - Pirinç + Krom Kaplama / Brass + Chrome Plated
7	Ringler / Seals	PTFE - Teflon
8	Salmastra	PTFE - Teflon

Ölçüler / Dimensions	Anma Basıncı / Nominal Pressure	25 Bar			
	Anma Çapı / Nominal Diameter	DN	15	20	25
	Vana Boyutları / Valve Dimensions	G	1 / 2"	3 / 4"	1"
		L	46	55	60
		H	40	45	50
Ağırlık / Weight	Kg	0,15	0,23	0,45	

T-2130 Pirinç Dövme / Forced Brass

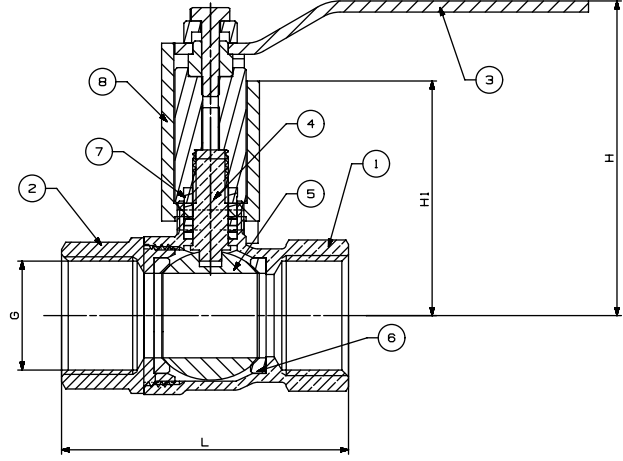

Genel Özellikler / General Specifications

Çalışma Sıcaklık Aralığı / Working Temperature : -10... +120 °C (25 Bar)

Standartlar / Standards

Sertifikalar / Certificates :

Tasarım / Design : TS EN 13547

Dış Standardı / Thread Standard : EN ISO 228-1

Testler / Tests : TS EN 12266-1

Uygulamalar / Applications

Sıcak ve soğuk su sistemleri, basınçlı hava, asit ve alkali özelliği bulunmayan sıvı akışkanlar
Hot and cold water systems, compressed air, non-acidic and non-flammable liquid fluids

Malzeme Özellikleri / Material Specifications	No	Parça Adı / Part Name	Malzeme / Material
	1	Gövde / Body	CuZn40Pb2 - CW617N - Pirinç Dövme / Forced Brass
	2	Kapak / Bonnet	CuZn40Pb2 - CW617N - Pirinç Dövme / Forced Brass
	3	Kol / Lever	Si37 - Çelik + Galvaniz + Vinil Kaplama / Steel + Galvanize Plated + Vinyl Coated
	4	Mil / Stem	CuZn40Pb2 - CW617N - Pirinç / Brass
	5	Küre / Ball	CuZn40Pb2 - CW617N - Pirinç + Krom Kaplama / Brass + Chrome Plated
	6	Ringler / Seals	PTFE - Teflon
	7	Salmastra	PTFE - Teflon
8	Boyun / Neck	Zamak Enjeksiyon / Zamak Injection	

Ölçüler / Dimensions	Anma Basıncı / Nominal Pressure	25 Bar						
	Anma Çapı / Nominal Diameter	DN	15	20	25	32	40	50
	Vana Boyutları / Valve Dimensions	G	1 / 2"	3 / 4"	1"	1 1 / 4"	1 1 / 2"	2"
		L	46	55	65	80	90	104
		H	65	68	81	86	113	120
		H1	45	48	55	60	81	90
		A	86		115		155	
	Ağırlık / Weight	Kg.	0,27	0,35	0,6	0,76	1,13	1,6

PIRİNÇ MINI KÜRESEL VANA (PN 16)

-BRASS MINI BALL VALVE (PN 16)



T-2160 Pirinç Dövme / Forced Brass

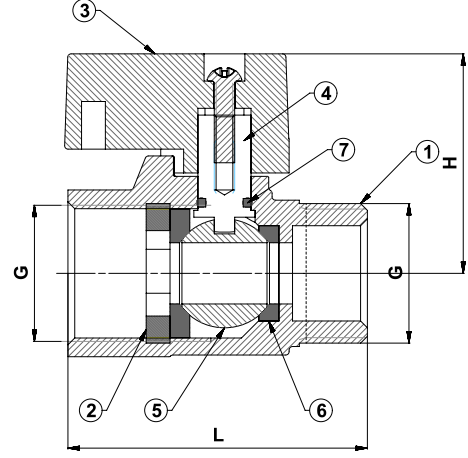

Genel Özellikler / General Specifications

Çalışma Sıcaklık Aralığı / Working Temperature : -10 ... +120 °C (16 Bar)

Standartlar / Standards

Sertifikalar / Certificates : CE, P3

Tasarım / Design : TS EN 13547

Diş Standardı / Thread Standard : EN ISO 228-1

Testler / Tests : TS EN 12266-1

Uygulamalar / Applications

Sıcak ve soğuk su sistemleri, basınçlı hava
Hot and cold water systems, compressed air

No	Parça Adı / Part Name	Malzeme / Material
1	Gövde / Body	CuZn40Pb2 - CW617N - Pirinç Dövme / Forced Brass
2	Kapak / Bonnet	CuZn40Pb2 - CW617N - Pirinç / Brass
3	Kol / Lever	Alüminyum Enjeksiyon + Elektrostatik Boya / Aluminum Injection + Electrostatic Painting
4	Mil / Stem	CuZn40Pb2 - CW617N - Pirinç / Brass
5	Küre / Ball	CuZn40Pb2 - CW617N - Pirinç + Krom Kaplama / Brass + Chrome Plated
6	Ringler / Seals	PTFE - Teflon
7	O-Ring	EPDM

Ölçüler / Dimensions	Anma Basıncı / Nominal Pressure	16 Bar		
	Anma Çapı / Nominal Diameter	DN	15	
	Vana Boyutları / Valve Dimensions	G	1 / 2"	
		L	46	
		H	32	
Ağırlık / Weight	Kg	0.140		

T-2210 Pirinç Dövme / Forced Brass

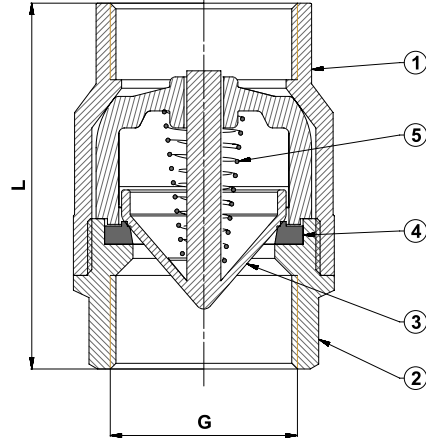

Genel Özellikler / General Specifications

Çalışma Sıcaklık Aralığı / Working Temperature: -10 ... +110°C (16 Bar)

Standartlar / Standards

Sertifikalar / Certificates:

Tasarım / Design: TS 10873

Diş Standardı / Thread Standard: EN ISO 228-1

Testler / Tests: TS EN 12266-1

Uygulamalar / Applications

Sıcak ve soğuk su sistemleri, basınçlı hava, asit ve alkali özelliği bulunmayan sıvı akışkanlar
Hot and cold water systems, compressed air, non-acidic and non-flammable liquid fluids

Malzeme Özellikleri / Material Specifications	No	Parça Adı / Part Name	Malzeme / Material
	1	Gövde / Body	CuZn40Pb2 - CW617N - Pirinç Dövme / Forced Brass
	2	Kapak / Bonnet	CuZn40Pb2 - CW617N - Pirinç Dövme / Forced Brass
	3	Klape / Clapper	Polimer Plastik / Polymer Plastic
	4	Conta / Gasket	NBR
5	Yay / Spring	X12CrNi18 8 - AISI302 - Paslanmaz Çelik / Stainless Steel	

Ölçüler / Dimensions	Anma Basıncı / Nominal Pressure	16 Bar									
	Anma Çapı / Nominal Diameter	DN	15	20	25	32	40	50	65	80	100
	Vana Boyutları / Valve Dimensions	G	1 / 2"	3 / 4"	1"	1 1 / 4"	1 1 / 2"	2"	2 1 / 2"	3"	4"
		L	49	53	58	67	71	79	93	102	120
Ağırlık / Weight	Kg	0.1	0.14	0.24	0.33	0.5	0,7	1,55	1,9	3	

Y TIPI PİSLİK TUTUCU (PİRİNÇ, DIŞLI, PN 16) -Y TYPE STRAINER (BRASS, THREADED, PN 16)



T-2220 Pirinç Dövme / Forced Brass

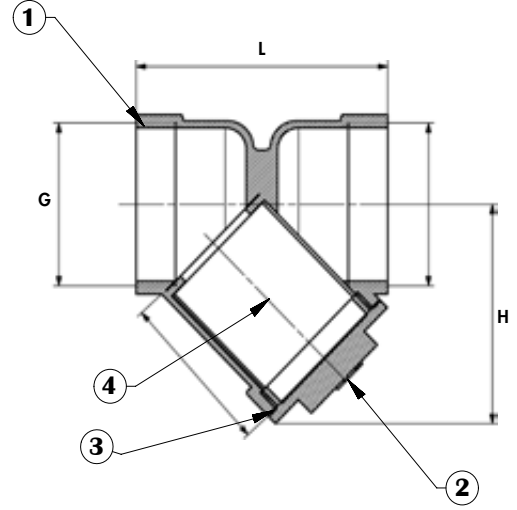

Genel Özellikler / General Specifications

Çalışma Sıcaklık Aralığı / Working Temperature : -10 ... +120 °C (16 Bar)

Standartlar / Standards

Sertifikalar / Certificates :  

Tasarım / Design : TS 11494

Diş Standardı / Thread Standard : EN ISO 228-1

Testler / Tests : TS EN 12266-1

Uygulamalar / Applications

Sıcak ve soğuk su sistemleri, basınçlı hava, doymuş buhar, asit ve alkali özelliği bulunmayan sıvı akışkanlar
Hot and cold water systems, compressed air, saturated steam, non-acidic and non-flammable liquid fluids

No	Parça Adı / Part Name	Malzeme / Material
1	Gövde / Body	CuZn40Pb2 - CW617N - Pirinç Dövme / Forced Brass
2	Kapak / Bonnet	CuZn40Pb2 - CW617N - Pirinç Dövme / Forced Brass
3	O-Ring	EPDM
4	Filtre / Filter	X5CrNi18 10 - AISI304 - Paslanmaz Çelik / Stainless Steel

Ölçüler / Dimensions	Anma Basıncı / Nominal Pressure	16 Bar								
	Anma Çapı / Nominal Diameter	DN	15	20	25	32	40	50	65	80
	Vana Boyutları / Valve Dimensions	G	1 / 2"	3 / 4"	1"	1 1 / 4"	1 1 / 2"	2"	2 1 / 2"	3"
		L	58	68	75	90	108	130	150	180
H	36	50	57	64	75	87	111	127		
Ağırlık / Weight	Kg	0,106	0,149	0,233	0,420	0,483	0,793	1,306	1,838	
Filtre / Filter		30 Mesh (600 Mikron-Micron)								

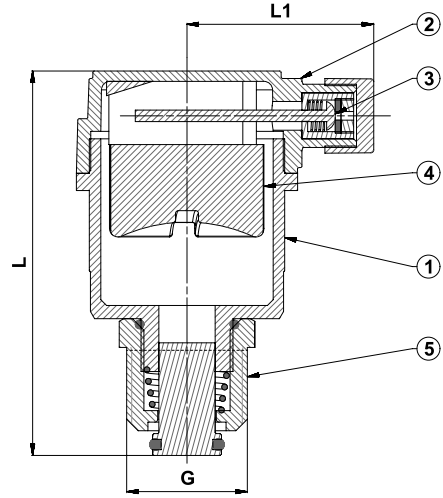

Genel Özellikler / General Specifications
Çalışma Sıcaklık Aralığı / Working Temperature : -10... +90 °C (10 Bar)

Standartlar / Standards

Sertifikalar / Certificates :

Tasarım / Design : TS 7817

Diş Standardı / Thread Standard : EN ISO 228-1

Testler / Tests : TS EN 12266-1

Uygulamalar / Applications

Sıcak ve soğuk su sistemleri
Hot and cold water systems

Malzeme Özellikleri / Material Specifications	No	Parça Adı / Part Name	Malzeme / Material
	1	Gövde / Body	CuZn40Pb2 - CW617N - Pirinç Dövme / Forced Brass
2	Kapak / Bonnet	CuZn40Pb2 - CW617N - Pirinç Dövme / Forced Brass	
3	Emniyet Subabı / Safety Valve	Ebonit / Ebonite	
4	Şamandıra / Float	Ebonit / Ebonite	
5	Çek Vana / Check Valve	CuZn40Pb2 - CW617N - Pirinç Dövme / Forced Brass	

Ölçüler / Dimensions	Anma Basıncı / Nominal Pressure	10 Bar		
	Anma Çapı / Nominal Diameter	DN	600	
	Vana Boyutları / Valve Dimensions	G	1 / 2"	
		L	71	
		L1	29	
Ağırlık / Weight	Kg	0.13		

DIN 2401 Malzeme & Sıcaklık Bağlantı Normu

PN	Vanalar				Sıcaklığa (°C) göre max. Çalışma basıncı (bar)																	
	Demir döküm	Sfero döküm	Çelik Döküm	Çelik	20 (120)	200	250	300	350	400	425	450	475	500	510	520	530	540	550			
1	GG 25	GGG 40		St-37/2	1																	
					1	1	1	1														
2,5	GG 25	GGG 40		St-37/2	2,5																	
					2,5	2	1,8	1,5														
6	GG 25	GGG 40	GS 45	St-37/2	6																	
					6	5	4,5	3,6														
10	GG 25	GGG 40	GS 45	St-37/2	10																	
					10	8	7	6														
16	GG 25	GGG 40	GS 45	St-37/2	16																	
					16	13	11	11														
25		GGG 40	GS-C 25	C 22 N	16	14	13	10														
					25																	
			GS-22 Mo4	15 Mo 3	25	20	18	16														
					25	22	20	17	16	14												
GS-17CrMO 55	13 CrMO 44	25	22	20	17	16	14															
		25	24	23	22	21	20	18	15	12	0											
40			GS-45.5	C 22 N	40	32	28	24														
					40	35	32	28	24	21												
			GS-22 Mo4	15 Mo 3	40	40	40	35	31	30	29	28										
					40	38	36	35	34	33	29	24	19	14								
63			GS-C 25	C 22 N	63	36	29	24														
					63	50	45	40														
			GS-22 Mo4	15 Mo 3	63	50	45	40	36	32												
					63	50	45	40	36	32												
100			GS-C 25	C 22 N	100	80	70	60														
					100	80	70	60	56	50												
			GS-22 Mo4	15 Mo 3	100	80	70	60	56	50												
					100	80	70	60	56	50												
160			GS-C 25	C 22 N	160	130	112	96														
					160	130	112	96	90	80												
			GS-22 Mo4	15 Mo 3	160	130	112	96	90	80												
					160	130	112	96	90	80												
250			GS-C 25	C 22 N	250	200	175	150														
					250	200	175	150	140	125												
			GS-22 Mo4	15 Mo 3	250	200	175	150	140	125												
					250	200	175	150	140	125												
320			GS-22 Mo4	C 22 N	320	250	225	192														
					320	250	225	192	180	160												
			GS-22 Mo4	15 Mo 3	320	250	225	192	180	160												
					320	250	225	192	180	160												
400			GS-C 25	C 22 N	400	320	280	240														
					400	320	280	240	225	200												
			GS-22 Mo4	15 Mo 3	400	320	280	240	225	200												
					400	320	280	240	225	200												



Ofis / Office
Oruç Reis Mh. Tekstilkent Cad. No: 12B Koza Plaza A Blok
Kat:26 No: 262 Esenler / İstanbul

+90 444 VANA (82 62)
Faks: +90 212 355 07 47

Fabrika & Merkez / Main Factory & Headquarters
Osmangazi Mh. 2653 Sk. No:7
Esenyurt / İstanbul

+90 444 VANA (82 62)
Faks: +90 212 355 07 47

 facebook.com/duyarvana

 linkedin.com/company/duyarvana

 twitter.com/duyarvana

 instagram.com/duyarvana

 youtube.com/c/duyarvana1965



www.duyarvana.com.tr
info@duyarvana.com.tr

www.duyarvalve.com
info@duyarvalve.com